

Antennas: An Overview

www.AtlantaRF.com



Atlanta RF

Services, Software & Designs

Presentation Content

Antennas: An Overview

1. What They Do.
2. Where are they used?
3. Antenna Types & Antenna Family.
4. Antenna Selection Trade-offs.
5. Antenna Performance Parameters.
6. Antenna Radiation Pattern.
7. Directional Gain: G .
8. Antenna Efficiency: η_{eff} .
9. Effective Capture Area: A_{eff} .
10. Half-Power Beamwidth: HPBW.
11. Plane Wave Polarization.
12. Power Transfer into Free Space
 - A. Friis' Transmission Equation.



13. Phased Array Antennas.
14. Characteristics of Antennas:
 - A. Half-Wave Dipole Antenna
 - B. Monopole Antenna
 - C. Loop Antenna
 - D. Axial-Mode Helical Antenna
 - E. Yagi Antenna
 - F. Log Periodic Antenna
 - G. Cavity-backed Spiral Antenna
 - H. Conical Spiral Antenna
 - I. Horn Antenna
 - J. Parabolic Antenna
 - K. Phased Array Antenna



Antennas: What they do

1. Antennas convert a guided electromagnetic (EM) wave that is enclosed inside a transmission line into a propagating wave radiating into free space, with a desired radiation efficiency and directional spatial radiation pattern. The propagating wave radiates from the antenna in straight radial lines.



2. The electrical current distributions within the antenna element produce the radiating wave in a specific form and direction (i.e.: spatial radiation pattern) defined by the antenna's structure and its surrounding environment.

3. Since an antenna element is a linear passive reciprocal device, it does not amplify. So "Gain" is a measure of its ability to concentrate RF power in a desired direction, when compared to the spherical radiation from an isotropic antenna. Hence, we use the term: Directional Gain.

4. An antenna's radiation pattern during a transmit period is the same radiation pattern during a receive period. As such, an antenna's performance characteristics do not depend on the direction of energy flow.

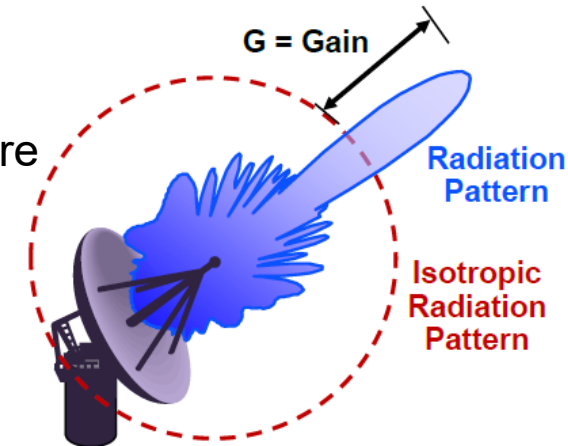

Examples of where Antennas are used

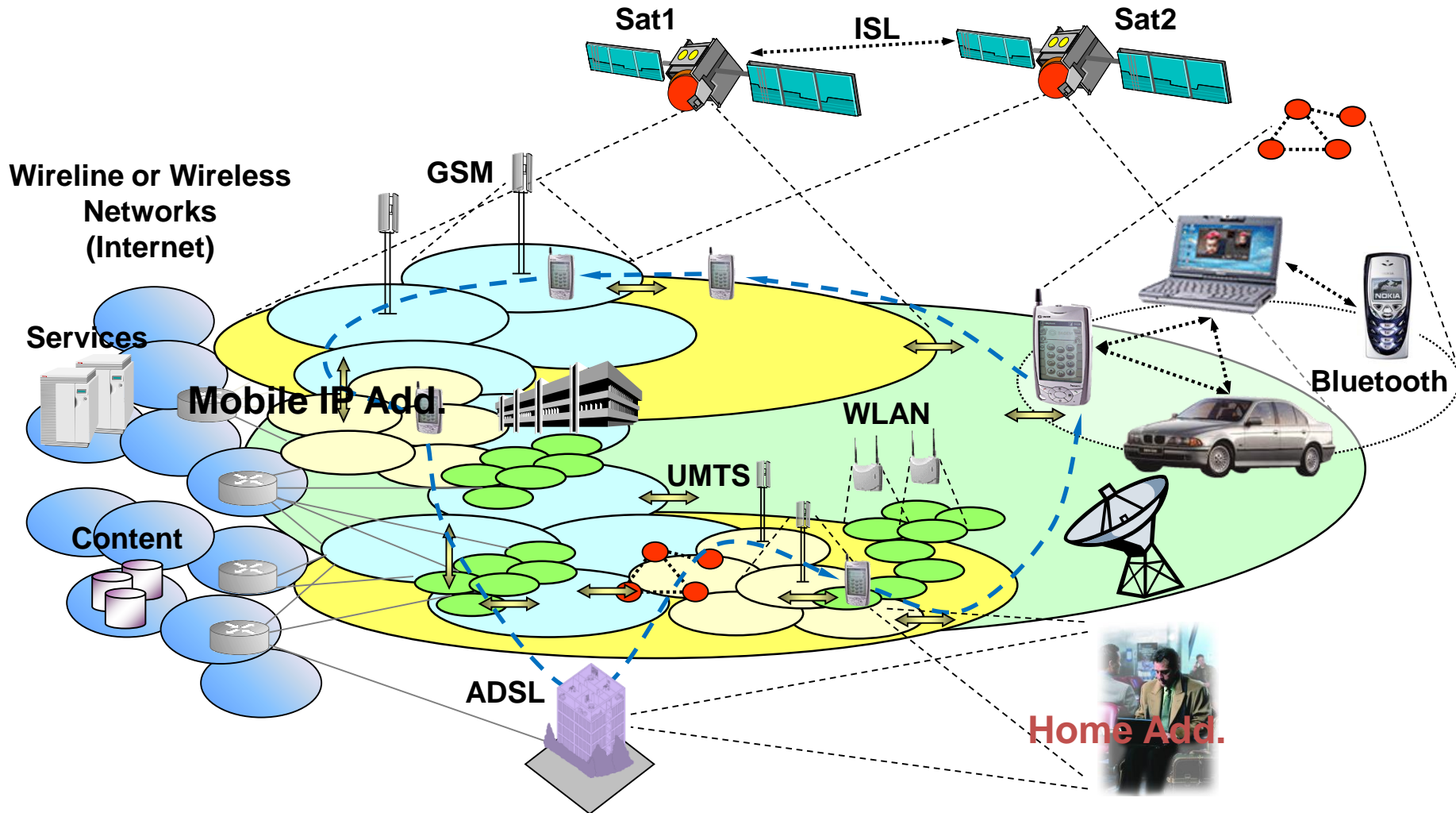

Atlanta RF

Services, Software & Designs

Antennas: Where are they used?

Wireless communications:

1. Personal Communications Systems.
2. Global Positioning Satellite (GPS).
3. Wireless Local Area Networks (WLAN).
4. Direct Broadcast Satellite (DBS) TV.
5. Mobile Communications.
6. Telephone Microwave/Satellite Links.
7. Broadcast Television and Radio, etc.

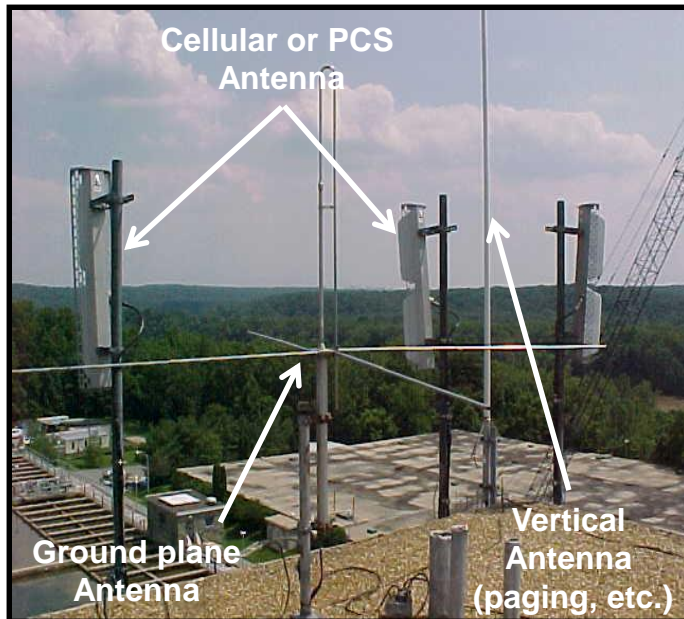

Remote Sensing:

1. Radar: Active remote sensing (Tx & Rx).
2. Military applications: Target search and tracking radar; Threat avoidance, etc....
3. Weather radar & Air traffic control.
4. Automobile speed detection.
5. Ground penetrating radar (GPR).
6. Agricultural applications.
7. Radiometry: Passive remote sensing - receive emissions.
8. And many, many more.

Unwanted Antennas:

1. Any opening/slot in a device/cable carrying a time-varying electrical/RF current.
2. Any discontinuity in a conducting structure irradiated by electromagnetic waves.
 - A. Electrical system radiating in vehicles.
 - B. Antenna masts or power-line wires.
 - C. Windmills or helicopter propellers.

Atlanta RF

Services, Software & Designs

Antenna Types

1. Antenna Shapes:

- A. Wire antennas: Dipole, helix, loop, & Yagi antennas.
- B. Aperture antennas: Horn & parabolic dish antennas.
- C. Printed antennas: Patch, printed dipole, spiral & slot antennas.

2. Antenna Gain Levels:

- A. High Gain (> 20 dB): Parabolic dish antenna.
- B. Medium Gain (10 to 20 dB): Horn, helix & Yagi antennas.
- C. Low Gain (< 10 dB): Dipole, loop, patch, slot & whip antennas.

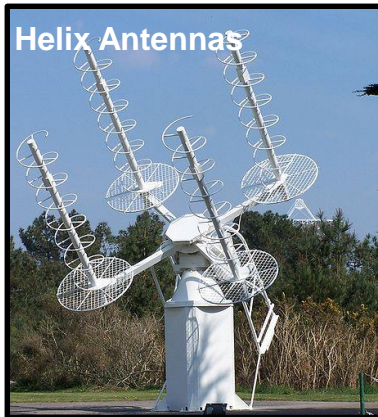

3. Antenna Beam Shapes:

- A. Omni-directional in azimuth:
 - 1) Linear Polarization: Biconical, dipole, loop & whip.
 - 2) Circular Polarization: Helix & conical spiral.
- B. Directional/Pencil beam:
 - 1) Linear: Parabolic, horn, log periodic & Yagi antenna.
 - 2) Circular: Parabolic, horn with polarizer, cavity-backed spiral.
- C. Fan beam: Antenna array.

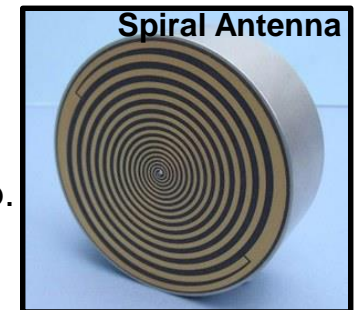

4. Operating Frequency Bandwidth:

- A. Wide Bandwidth: Biconical, conical spiral & log periodic antennas.
- B. Moderate Bandwidth: Horn & Parabolic dish antennas.
- C. Narrow Bandwidth: Dipole, helix, loop, patch, slot, whip & Yagi antennas.

Atlanta RF

Services, Software & Designs

Antenna Family

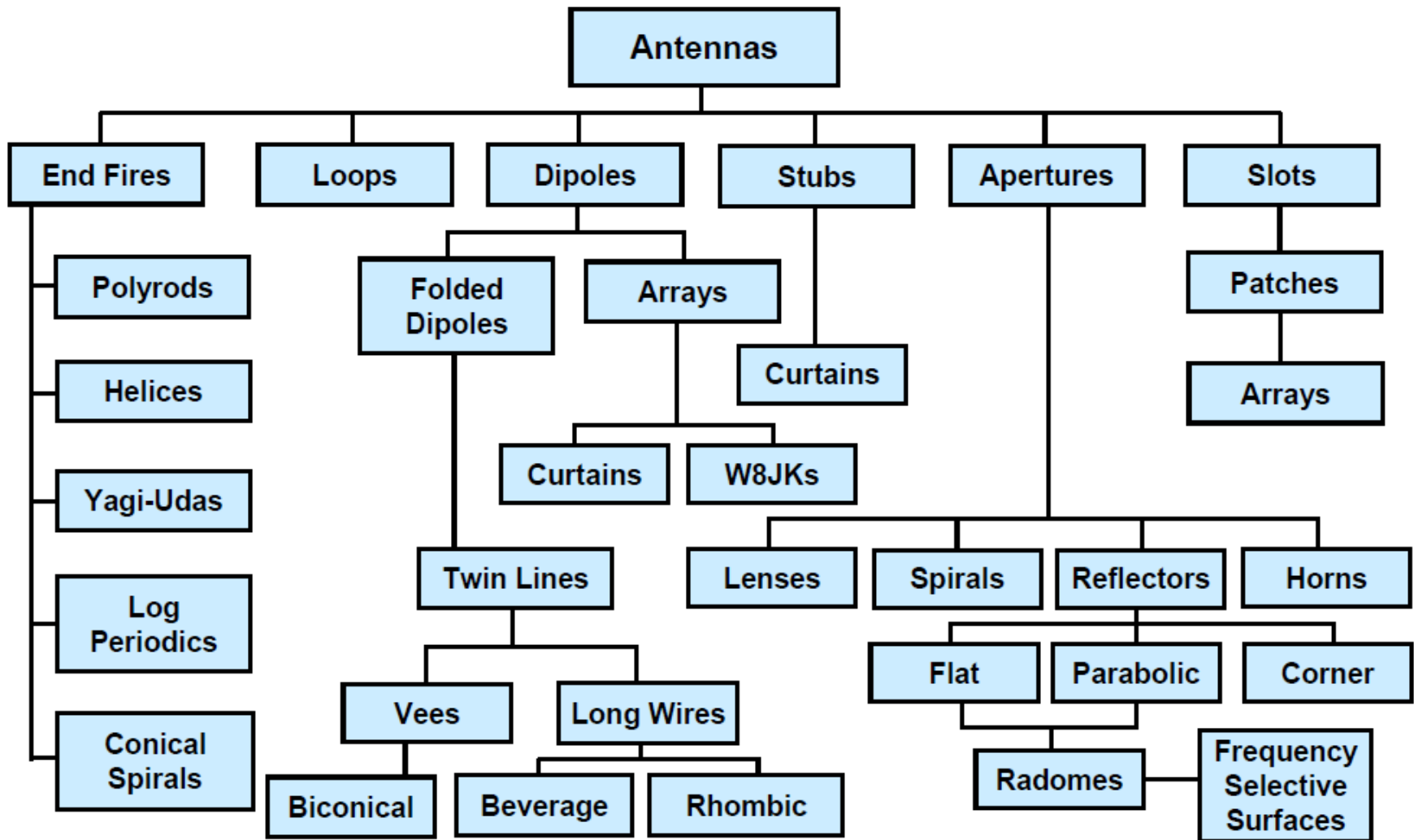

Antenna Selection Trade-offs

1. Selection of the best antenna is highly dependent on its intended use and application in a system or network.
2. Design trade-offs effecting an antenna's selection include:
 - A. Frequency of operation: F_o & frequency bandwidth: BW.
 - 1) More often: Multiple center frequencies with various bandwidths.
 - 2) Bandwidth is often defined when VSWR < 2.0:1 versus frequency.
 - B. Angular Coverage (Radiation Pattern)
 - 1) Half-Power Beamwidth: θ_{3dB} and/or ϕ_{3dB} .
 - 2) Front-to-Back Ratio: F/B.
 - 3) Pattern Nulls; First Null Beamwidth (FNBW).
 - C. Directional Gain: $G = \eta_{eff} D_{max}$
 - D. Polarization: Linear, Circular, Elliptical.
 - E. Cross-Polarization rejection (Cross-Pol) or axial ratio.
 - F. RF power handling: CW and/or peak RF power.
 - G. Physical size & weight: Fits inside desired package.
 - H. Vulnerability to weather & physical abuse (i.e.: cell phones).
 - I. Cost: Initial cost & cost of ownership.

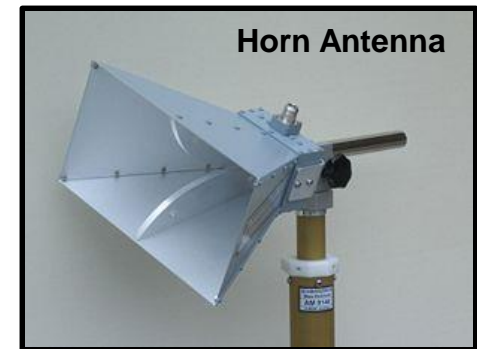
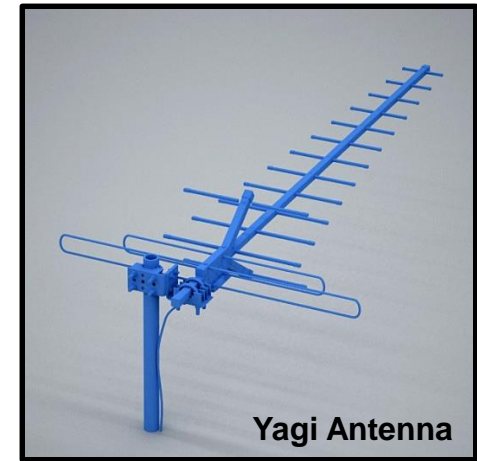

Antenna Performance Parameters

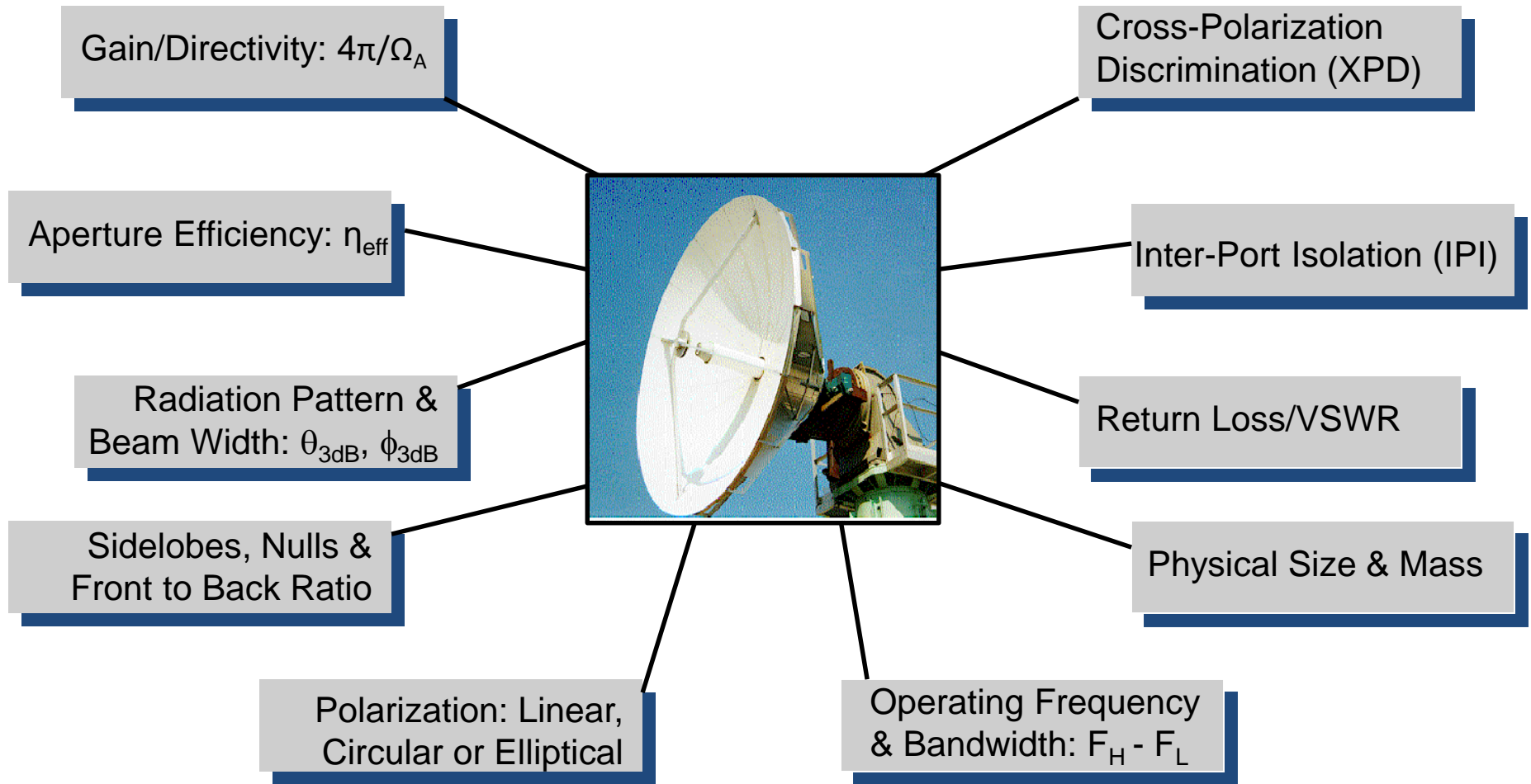

Antenna's Radiation Pattern: Definition

IEEE Standard Definition:

“A mathematical function or a graphical representation of the radiation properties of the antenna as a function of space coordinates. In most cases, the radiation pattern is determined in the far-field region and is represented as a function of the directional coordinates (ϕ and θ). Radiation properties include power flux density, radiation intensity, field strength, directivity, phase or polarization.”

Polar coordinate system:

ϕ : **Azimuth**: Angle in horizontal plane.
(Top down view).

θ : **Elevation**: Angle above horizontal plane.
(Side view).

The angle(s) at which maximum radiation occurs is called “boresight”.

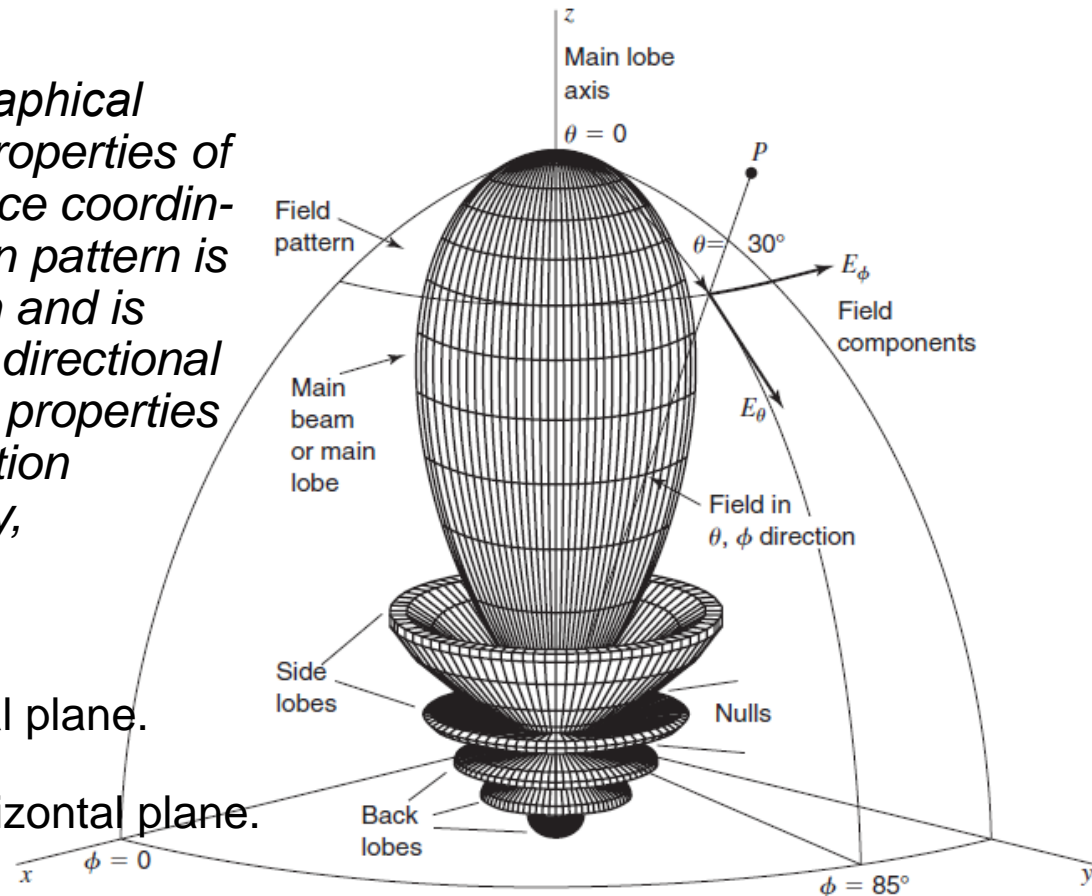

Typical Radiation Pattern: Polar Plot

Atlanta RF

Services, Software & Designs

Types of Radiation Patterns from Antennas

1. Isotropic Radiation: Radiation pattern of an antenna having equal radiation in all directions: Spherical radiation pattern. Not physically achievable, but is used to define other antenna's parameters. Represented by a sphere whose center coincides with the location of the isotropic radiator.

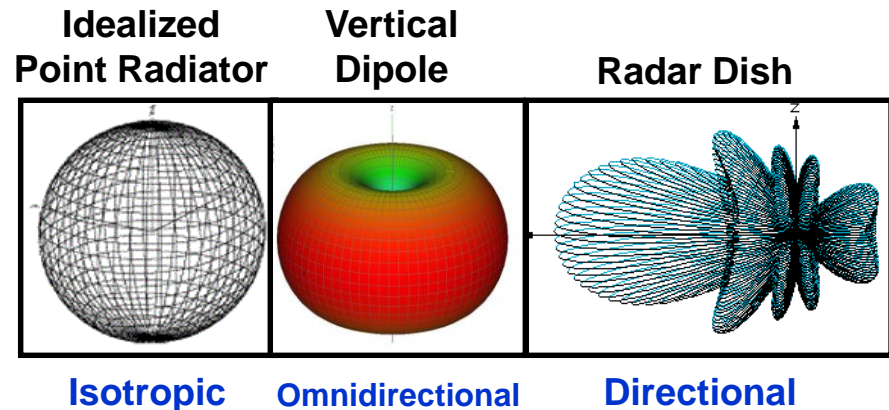

- 2. Omnidirectional Radiation:** Radiation pattern provides general coverage in all directions. Usually, wide angular horizontal coverage and limited angular vertical coverage. Donut-shaped radiation pattern. Useful in mobile phone applications.
- 3. Directional Radiation:** Radiation pattern characterized by a more efficient radiation in one direction than another. Main beam focused in a desired angular direction. Types: Broadside, Intermediate and Endfire. Spotlight or flashlight-shaped radiation pattern.
- 4. Principal Plane Radiation Patterns:** The E-plane and H-plane radiation patterns of a linearly polarized antenna.
- A. E-plane: The plane containing the electric field vector and the direction of maximum radiation.
 - B. H-plane: The plane containing the magnetic field vector and the direction of maximum radiation.

Radiation Pattern Characteristics

- 1. Boresight:** Radiation lobe in the direction of maximum radiation.
- 2. Gain:** Absolute gain or relative gain, dB.
- 3. HPBW:** Half Power Beamwidth, degrees.
 - A. A measure of how broad or narrow the focus of radiated power density is.
 - B. Measured both horizontally and vertically.
 - C. Angle where signal is 3dB below main beam.
- 4. FNBW:** First Null Beam Width, degrees.
 - A. Angle where destructive interference of radiated energy creates the first null in the radiation pattern.
 - B. Often, $FNBW = 2 \times HPBW$, degrees.
- 5. Sidelobes:** Direction & depth of sidelobe radiation, dB.
- 6. Pattern Nulls:** Direction & depths of no radiation, dB.
- 7. F/B:** Front-to-back ratio = Main Lobe (dB) – Back Lobe, dB.
 - A. Ratio of the maximum signal radiating from the main/front beam to the maximum signal radiating from the back (180°) of the antenna.

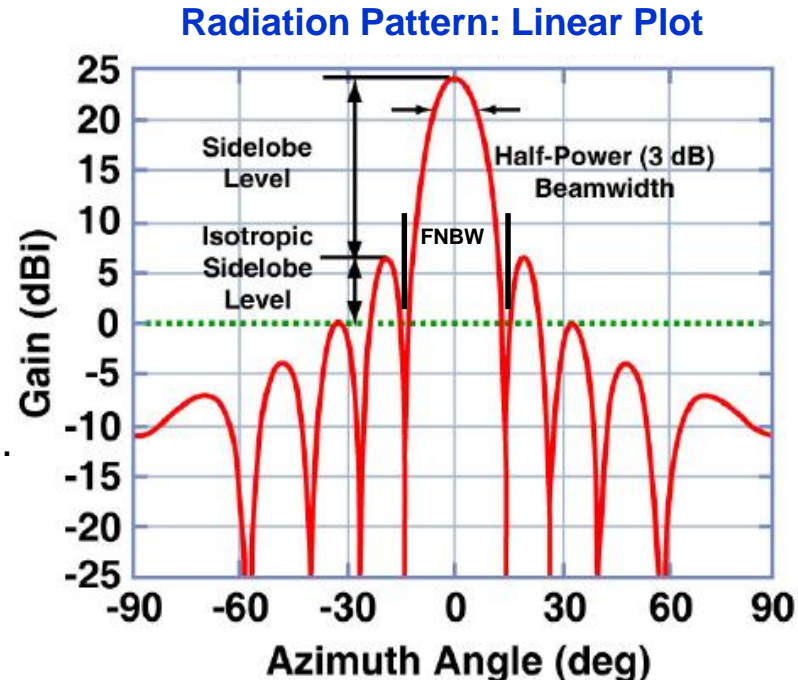

Typical Radiation Pattern Plots

Polar Diagram Plot & Rectangular/Linear Plot

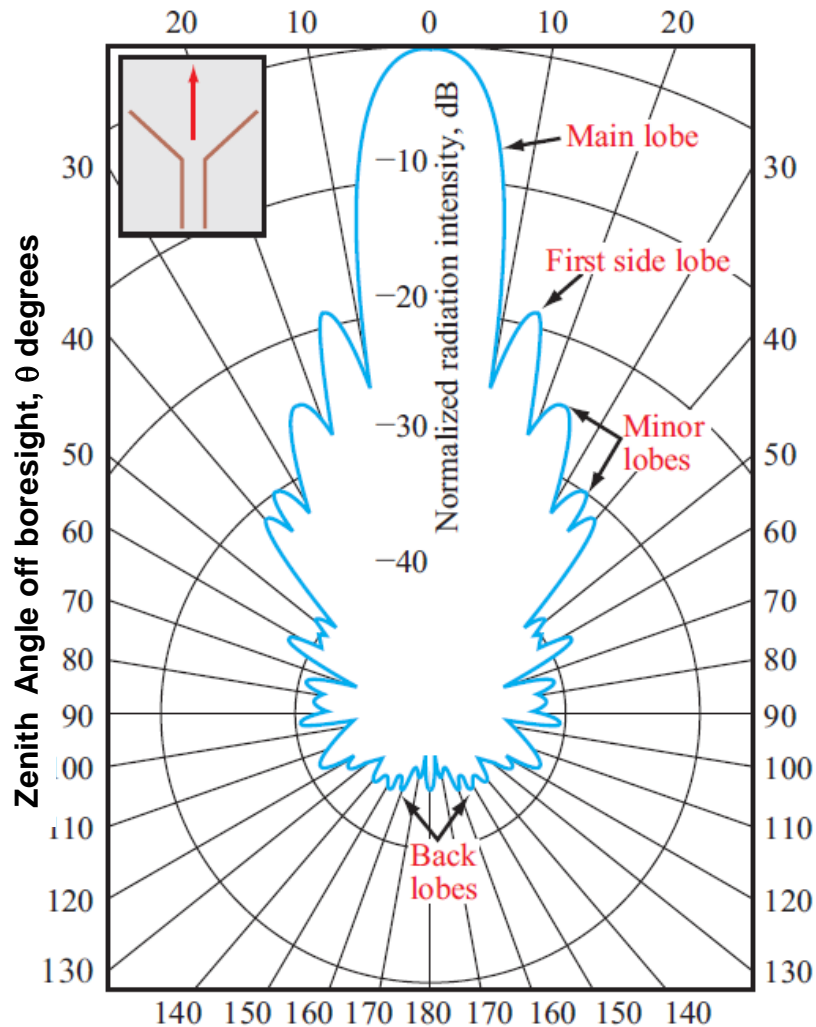

(a) Polar Diagram

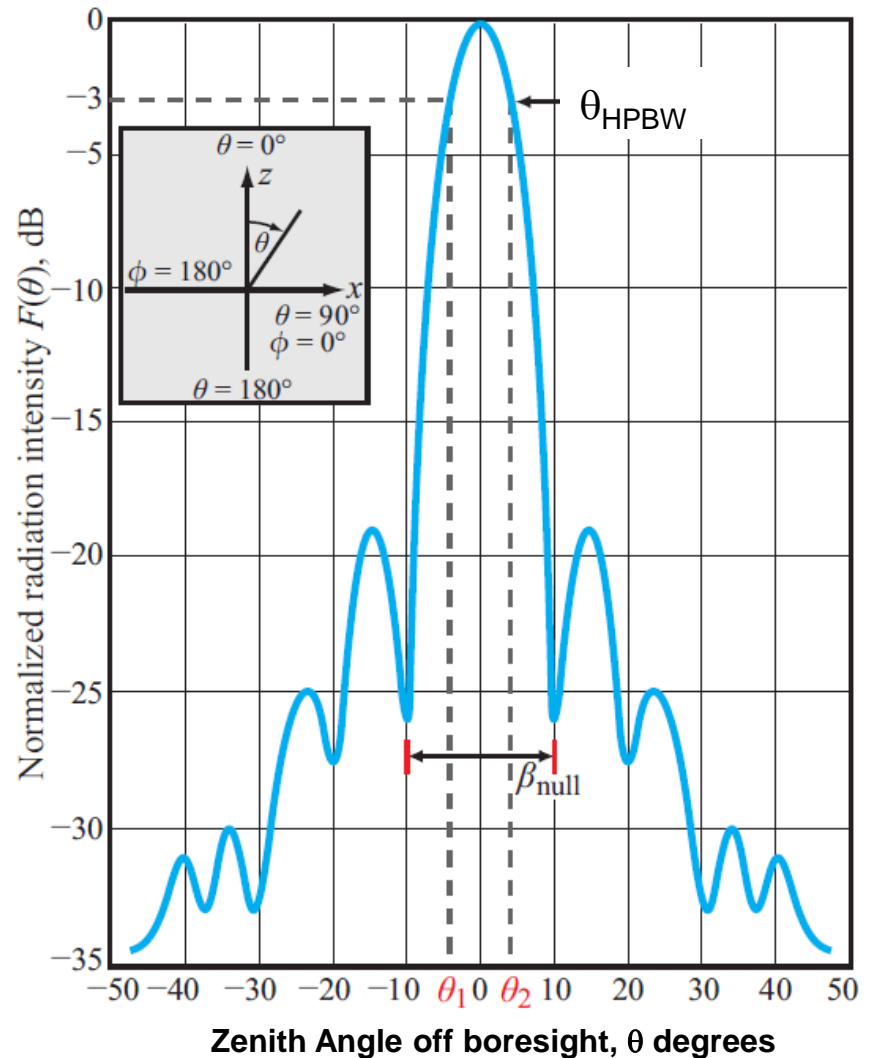

(b) Rectangular/Linear Diagram

Depiction: Antenna Gain versus Azimuth (Phi: ϕ) and Elevation (Theta: θ)

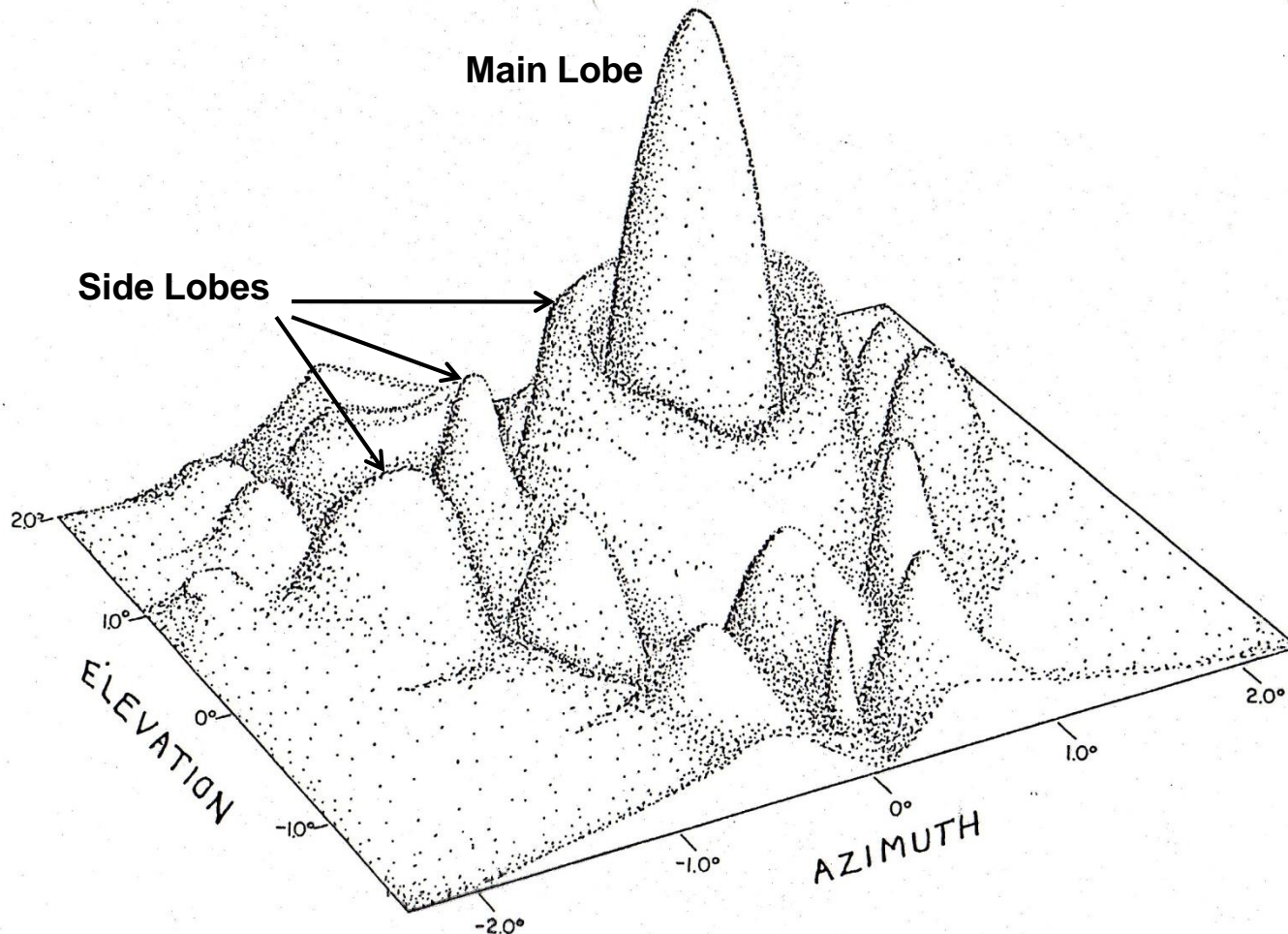

ϕ : **Azimuth**: Angle in horizontal plane.
 θ : **Elevation**: Angle above horizontal plane.

Atlanta RF

Services, Software & Designs

Antenna Directional Gain: $G = \eta_{\text{eff}} D$

1. The directivity, $D(\theta, \phi)$, of an antenna is the ratio of maximum radiation intensity in the main beam direction to the radiation intensity averaged over all directions (sphere). Directivity is a measure of how much radiated power, P_o , is concentrated in a particular spatial direction: ϕ (Az) and θ (EL).
2. The gain, $G(\theta, \phi)$, of an antenna is an actual or realized quantity which is less than the directivity D , due to ohmic and passive losses in the antenna or its radome (if enclosed).
3. The definition of gain does not include impedance mismatch nor polarization mismatch. Those factors are separately accounted for in the link budget.

$$G = \eta_{\text{eff}} D = \frac{4\pi A_e}{\lambda^2} = \frac{4\pi f^2 A_e}{c^2}$$

where:

- G = Antenna gain (dimensionless).
- η_{eff} = Radiation efficiency of antenna.
- A_e = Effective aperture area, meter².
- f = Signal's frequency, Hertz.
- c = Speed of light (3×10^8 meters/second).
- λ = Signal's wavelength, meters = c/f .

Total power radiated :

$$P_o = \int_0^{2\pi} \int_0^\pi \Phi(\theta, \phi) \sin \theta d\theta d\phi$$

Average radiation intensity :

$$\Phi_{\text{avg}} = \frac{P_o}{4\pi}$$

Atlanta RF

Services, Software & Designs

Antenna Gain

$$Gain = \eta_{eff} D = \frac{4\pi A_e}{\lambda^2} = \frac{4\pi f^2 A_e}{c^2}$$

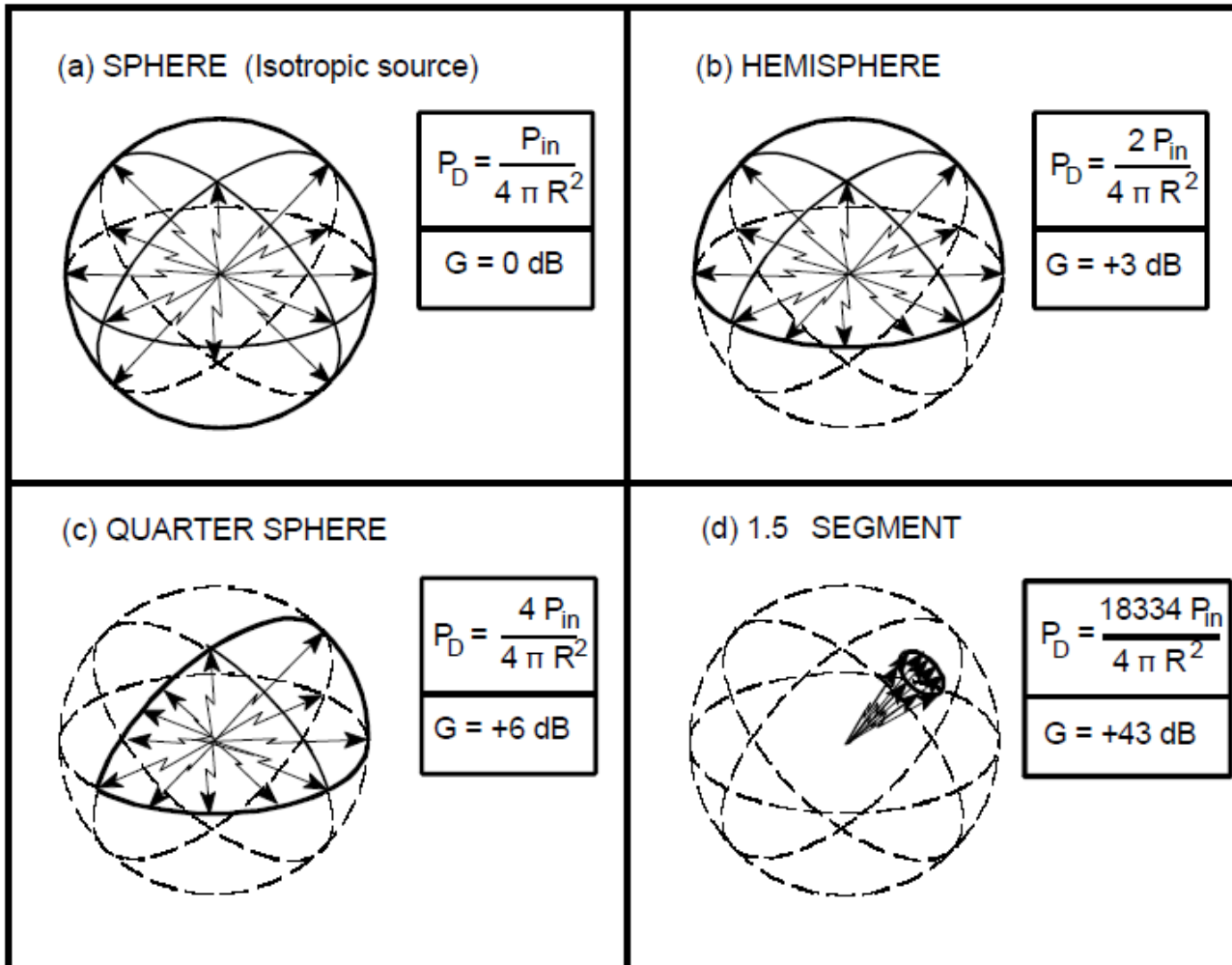

Gain of an Antenna in a Rectangular sector

1. For an ideal antenna with uniform distribution and no losses, its Gain is equal to the area of an isotropic sphere ($4\pi r^2$) divided by the area of the sector, or cross-sectional area:

$$\text{Gain} = \frac{\text{Area of sphere}}{\text{Area of Antenna pattern}}$$

2. If the antenna pattern has a rectangular area, then the antenna's sector Area = $a \times b = r^2 \sin\theta \sin\phi$, where: $a = r \sin\theta$; $b = r \sin\phi$, so:

$$\text{Gain} = \frac{4 \cdot \pi \cdot r^2}{r^2 \sin \theta \sin \phi} = \frac{4 \cdot \pi}{\sin \theta \sin \phi}$$

For small angles, $\sin \phi = \phi$, in radians, then:

$$\text{Gain} \approx \frac{4 \cdot \pi}{\theta \phi (\text{radians})} = \frac{41,253}{\theta \phi (\text{degrees})}$$

3. For a highly directional antenna with a small beamwidth ($\sim 1^\circ$) and an average radiation efficiency of $\eta_{\text{eff}} = 70\%$:

$$\text{Gain} \approx \frac{0.70 \times 41,253}{\theta \phi (\text{degrees})} = \frac{28,877}{\theta \phi (\text{degrees})} = 44.6 \text{ dB}$$

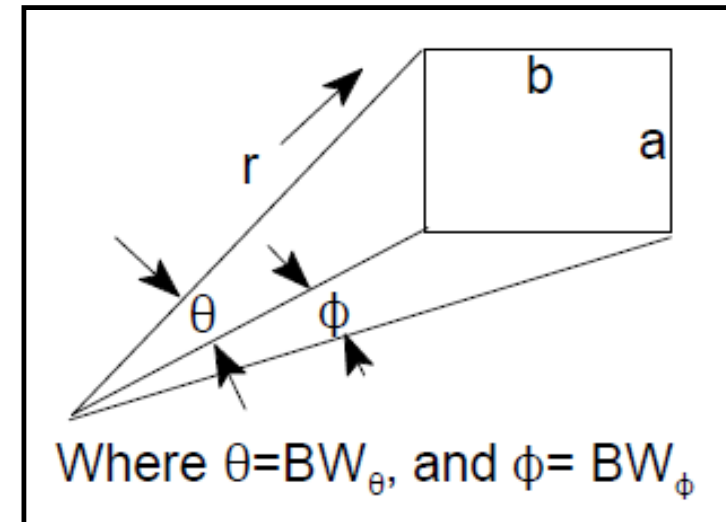

Atlanta RF

Services, Software & Designs

Gain of an Antenna in an Elliptical sector

1. For an ideal antenna with uniform distribution and no losses, its Gain is equal to the area of an isotropic sphere ($4\pi r^2$) divided by the area of the sector, or cross-sectional area:

$$\text{Gain} = \frac{\text{Area of sphere}}{\text{Area of Antenna pattern}}$$

2. If the antenna pattern has an elliptical area, then the antenna's sector Area = $\pi(a b) = (\pi r^2 \sin\theta \sin\phi)/4$, where: $a = (r \sin\theta)/2$; $b = (r \sin\phi)/2$, so:

$$\text{Gain} = (4\pi r^2) \left[\frac{4}{\pi r^2 \sin\theta \sin\phi} \right] = \frac{16}{\sin\theta \sin\phi}$$

For small angles, $\sin\phi = \phi$, in radians, then:

$$\text{Gain} \approx \frac{16}{\theta \phi \text{ (radians)}} = \frac{52,525}{\theta \phi \text{ (degrees)}}$$

3. For a highly directional antenna with a small beamwidth ($\sim 1^\circ$) and an average radiation efficiency of $\eta_{\text{eff}} = 55\%$:

$$\text{Gain} \approx \frac{0.55 \times 52,525}{\theta \phi \text{ (degrees)}} = \frac{28,888}{\theta \phi \text{ (degrees)}} = 44.6 \text{ dB}$$

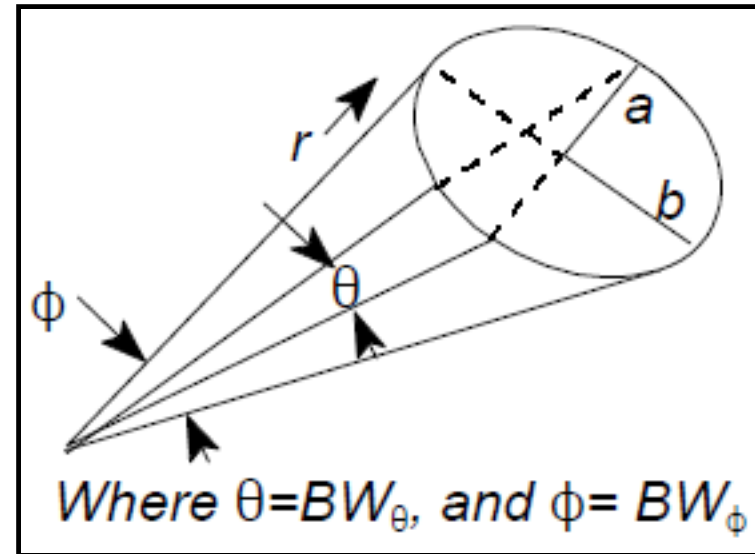

Atlanta RF

Services, Software & Designs

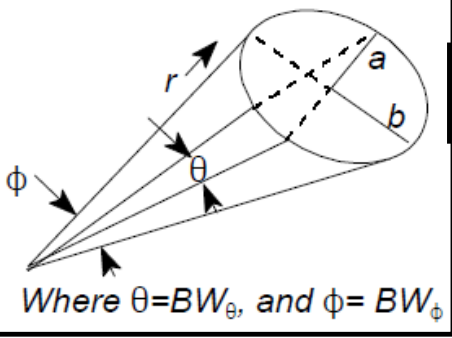

$$\text{Gain}_{\text{Elliptical}} \approx \frac{52,525}{\theta \phi \text{ (degrees)}}$$

$$\text{Gain}_{\text{rec}} \approx \frac{41,253}{\theta \phi \text{ (degrees)}}$$

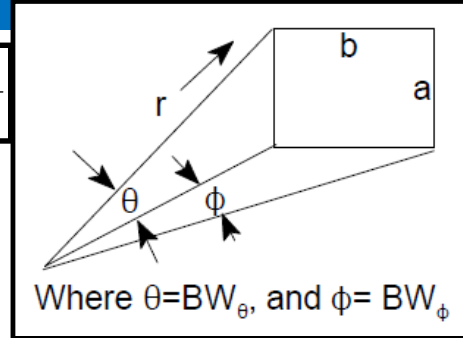

Antenna Gain vs Sector Area



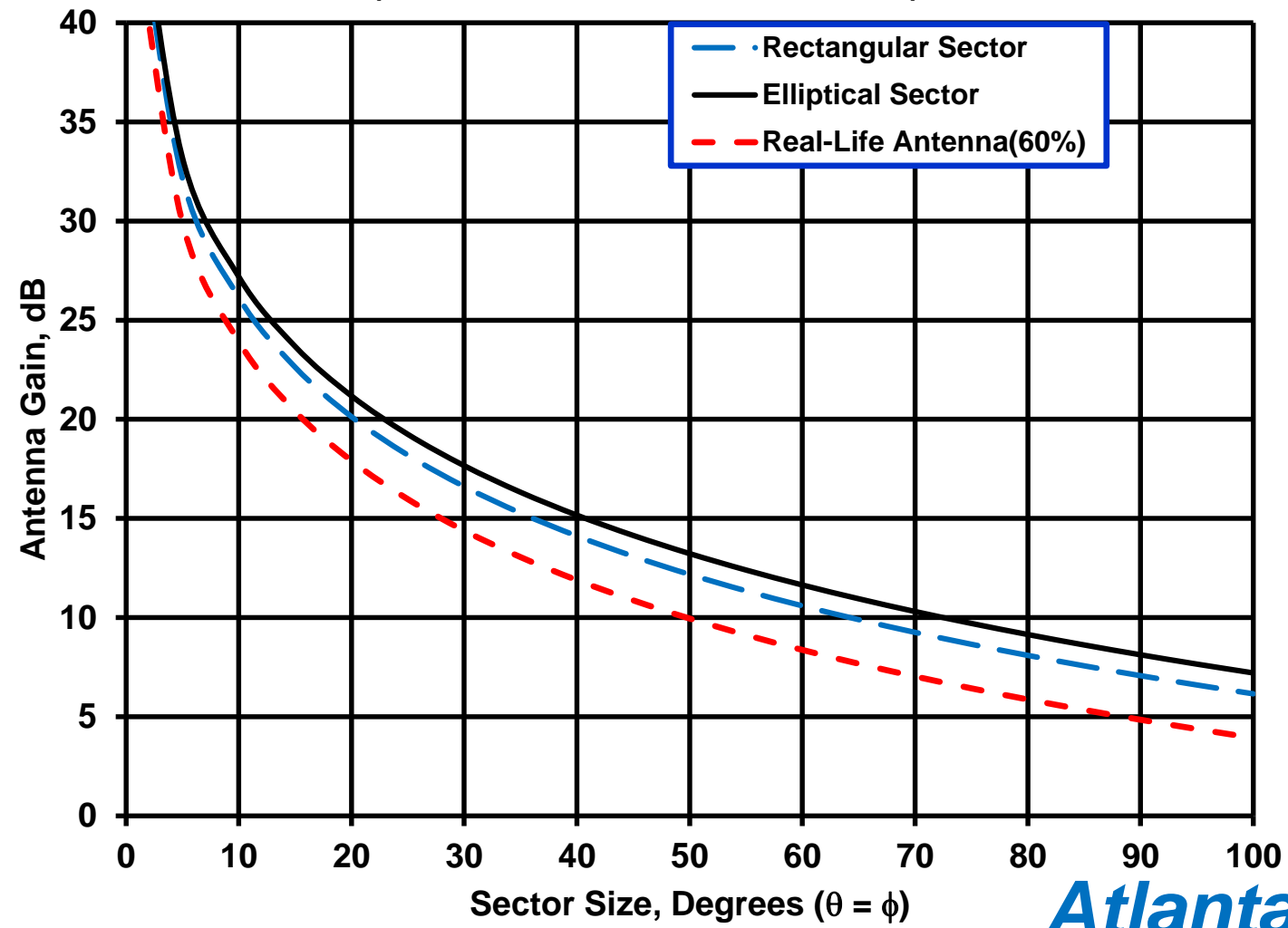

(Uniform illumination & no losses)



Atlanta RF

Services, Software & Designs

Directive Gain & Beamwidths for Aperture-type Antennas

Aperture-Type	Beamwidth (From Aperture)	Directive gain (From Aperture)	Directive gain (From Beamwidth)	Antenna Efficiency (Aperture illumination Efficiency)
Uniformly illuminated circular aperture-hypothetical parabola  18 dB side-lobe level	$\theta = \frac{58\lambda}{a}$ $\theta = \theta_1 = \theta_2$	$g_d = \frac{15 a^2}{\lambda^2}$ $g_d = \frac{9.87 a^2}{\lambda^2}$	$g_d = \frac{52,525}{\theta^2}$ $\theta = \theta_1 = \theta_2$	100%
Uniformly illuminated rectangular aperture or linear array  13 dB side-lobe level	$\theta_1 = \frac{51\lambda}{a}$ $\theta_2 = \frac{51\lambda}{b}$	$g_d = \frac{1.6 ab}{\lambda^2}$	$g_d = \frac{41,253}{\theta_1 \theta_2}$	100%
Rectangular horn a) Polarization plane: E-plane  13 dB side-lobe level ----- b) Orthogonal polarization plane: H-plane  26 dB side-lobe level	$\theta_1 = \frac{56\lambda}{a_E}$ $\theta_2 = \frac{67\lambda}{a_H}$	$g_d = \frac{7.5 a_E a_H}{\lambda}$	$g_d = \frac{31,000}{\theta_1 \theta_2}$	60%
Nonuniformly illuminated circular aperture (10 dB taper)-normal parabola  26 dB side-lobe level	$\theta = \frac{72\lambda}{a}$ $\theta = \theta_1 = \theta_2$	$g_d = \frac{5 a^2}{\lambda^2}$	$g_d = \frac{27,000}{\theta^2}$ $\theta = \theta_1 = \theta_2$	50%
	$a \gg \lambda$	$G_d = 10 \log_{10} g_d \text{ dB}$	$G_d = 10 \log_{10} g_d \text{ dB}$	

Benefits of Directional Antennas

1. Reasons for wanting Directive Antennas:

- A. Lower receive noise when “looking” only at a small sector of free space.
- B. Stronger signal when “looking” in the direction of the transmit power source.
- C. Remote sensing (Radar): When interested in properties of a small section of space.
- D. Can be used to spatially filter-out signals that are unwanted.
- E. Can provide radiation coverage to only desired service region.

2. Typical antenna gain and half-power beamwidths, HPBW:

Type of Antenna	Gain	HPBW
Isotropic	0dBi	360°x360°
Dipole	2dBi	360°x120°
Helix (10 turn)	14dBi	35°x35°
Small parabolic dish	16dBi	30°x30°
Large parabolic dish	45dBi	1°x1°

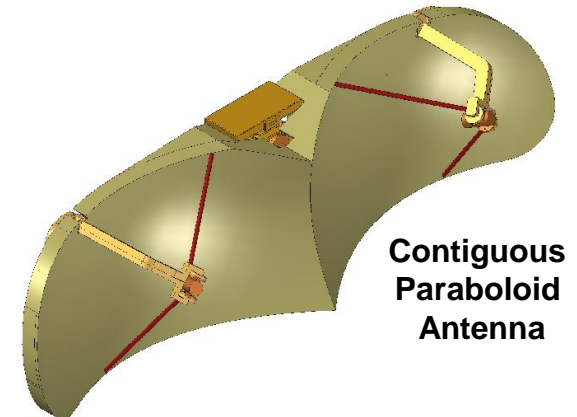

Antenna Efficiency: η_{eff}

1. The efficiency to radiate RF power delivered to the antenna accounts for the various losses in the antenna, such as spillover loss, power radiated in the sidelobes, dielectric loss, conduction loss, blockage from any supporting structure, RMS surface deviations, reflection loss and polarization mismatch loss.

$$\eta_{\text{eff}} = \frac{\text{Gain}}{\text{Directivity}} = \frac{P_{\text{radiated}}}{P_{\text{input}}} = \frac{P_{\text{radiated}}}{P_{\text{radiated}} + P_{\text{loss}}}$$

2. Where: $\eta_{\text{eff}} = \eta_r \eta_t \eta_s \eta_a$

A. η_{eff} : Aperture efficiency.

B. η_r : Radiation efficiency.

C. η_t : Taper efficiency or utilization factor.

D. η_s : Spillover loss (reflector antennas) accounts for the RF energy spilling beyond the edge of the reflector into the back lobes of the antenna. Major contributor to the antenna's noise temperature.

E. $\eta_r \eta_s$ is called η_i : Illumination efficiency, which accounts for the nonuniformity of the illumination, phase distribution across the antenna surface, and power radiated in the sidelobes.

F. η_{cr} : Cross-polarization efficiency. Due to cross-polarization on-axis.

3. Typical antenna efficiency: $\eta_{\text{eff}} = 0.5$ to 0.75 (= 50% to 75%).

Typical efficiency for a large Cassegrain Antenna

Efficiency Factor	Efficiency (%)	Loss (dB)
Illumination Efficiency.	98.7	0.06
Subreflector Spill-Over	88.3	0.54
Main Reflector Spill-Over	96.0	0.18
Blockage Losses	92.6	0.33
Manufacturing Losses	92.4	0.34
Feed Ohmic Losses	95.5	0.2
Total Efficiency =	68.4%	1.65dB



Gain at boresight for a 30 meter diameter Cassegrain Antenna at 4 GHz:

- Gain = $10 \log_{10} [0.684(\pi \times 30\text{meter} [4/0.3])^2]$, dBi.
- Gain = 60.3 dBi.

Antenna Effective Capture Area: A_e

1. Antenna Effective Area: A_e is measure of the effective absorption area presented by an antenna to an incident plane wave.
2. Only depends on the antenna's gain, G , and wavelength, λ :

$$A_e = \eta_{eff} A_{physical} = \frac{\lambda^2}{4\pi} D = \eta_{eff} \frac{\lambda^2}{4\pi} G, m^2$$

where:

- $\eta_{eff} = A_e / A_{physical} =$ Aperture efficiency.
- $A_{physical}$: Physical area of antenna's aperture, square meters.

3. For a parabolic dish antenna with diameter d and a 65% efficiency:

$$A_e = \eta_{eff} A_{physical} = 0.65 \frac{\pi d^2}{4}, m^2$$

4. Directional Gain for a parabolic dish antenna:

$$Gain = \eta_{eff} \left(\frac{\pi d}{\lambda} \right)^2$$

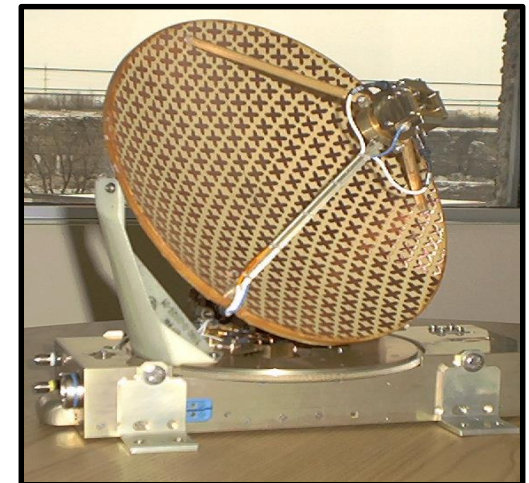

Atlanta RF

Services, Software & Designs

Effective Capture Area of typical Antennas

Type of Antenna	Effective Area A_e , meters ²	Directional Gain _{max}
Isotropic	$A_{isotropic} = \frac{\lambda^2}{4\pi}$	1 (0dB)
Infinitesimal Dipole or Loop	$1.5A_{isotropic}$	$1.5 \sin^2\theta$ (1.76dB)
Half-Wave Dipole	$1.64A_{isotropic}$	1.64 (2.14dB)
Horn (mouth area: A)	$0.81 \cdot A$	$10 \cdot A / \lambda^2$
Parabolic dish (with face area A)	$0.56 \cdot A$	$7 \cdot A / \lambda^2$

$$Gain = \eta_{eff} D = \frac{4\pi A_e}{\lambda^2} = \frac{4\pi f^2 A_e}{c^2}$$

Antenna's Half-Power Beamwidth (HPBW)

1. Beamwidth is associated with the lobes in the antenna's radiation pattern. It is defined as the angular separation between two identical points on the opposite sides of the main lobe.
2. The most common type of beamwidth is the half-power (3 dB) beamwidth (HPBW).
3. Another frequently used measure of beam width is the first-null beamwidth (FNBW), which is the angular separation between the first nulls on either sides of the main lobe. $FNBW \sim 2 * HPBW$.
4. Beamwidth defines the resolution capability of the antenna: i.e., the ability of the system to separate two adjacent targets.
5. For antennas with rotationally symmetric lobes, the directivity can be approximated:

$$D \approx \frac{4\pi}{\theta_{3dB} \phi_{3dB} \text{ (radians)}} = \frac{41,253}{\theta^{\circ}_{3dB} \phi^{\circ}_{3dB}}$$

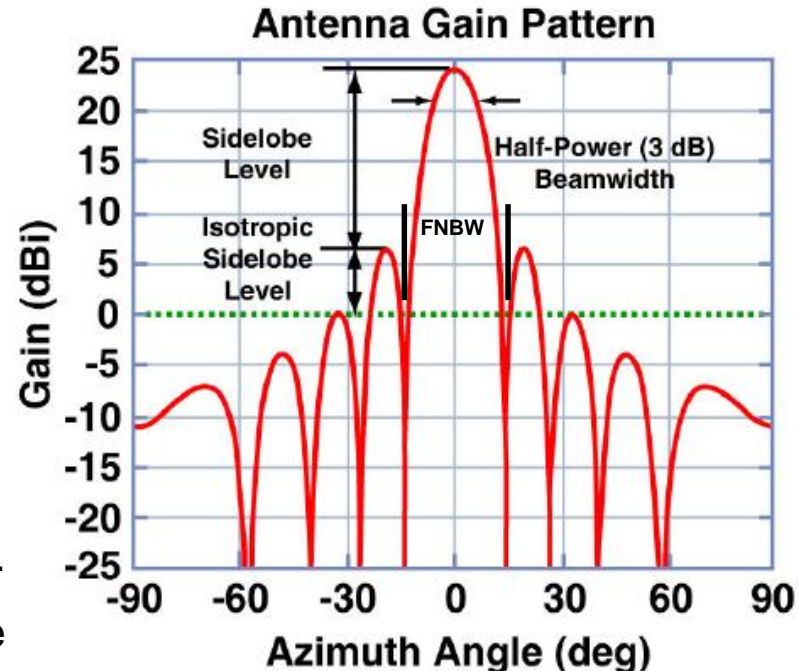

Typical Half-Power Beamwidths of Antennas



Omni Antenna

Antenna Type	Horizontal Beamwidth	Vertical Beamwidth
Omnidirectional	360°	7° to 80°
Patch/Panel	30° to 180°	6° to 90°
Yagi	30° to 78°	14° to 64°
Sector	60° to 180°	7° to 17°
Parabolic Dish	<4° to ~25°	<4° to ~21°



Sector Antennas



Patch Antenna

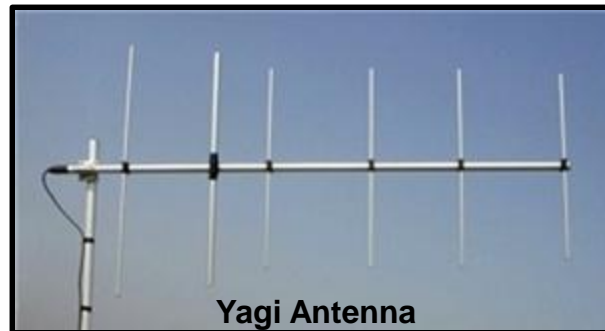

Yagi Antenna



Parabolic Dish Antenna

Atlanta RF

Services, Software & Designs

Plane Wave Polarization

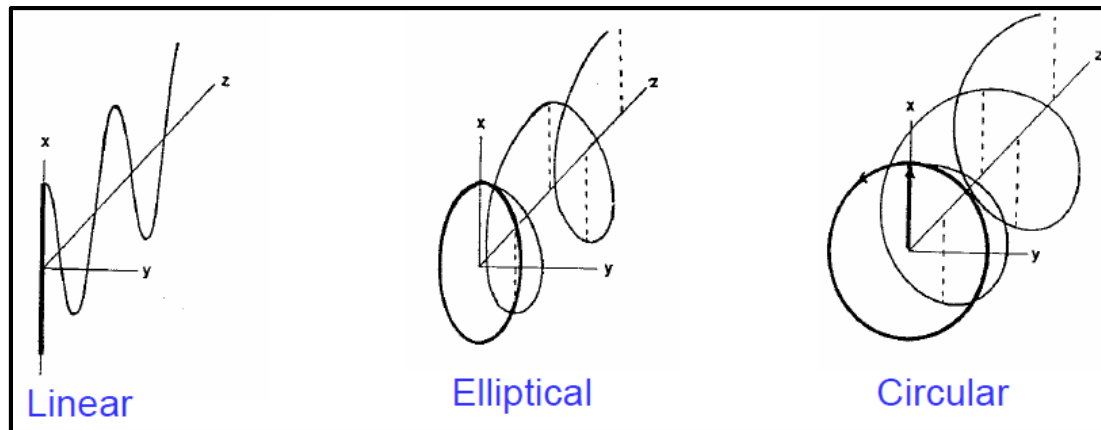

1. Linear Polarization:

- A. Vertical polarization has its electric field vector perpendicular to the earth (AM radio).
- B. Horizontal Polarization has its electric field vector horizontal to the earth (TV).
- C. Oblique Polarization has its electric field vector tilted to the earth.

2. Circular Polarization:

- A. RHCP: Right-Hand Circular Polarization has its electric field vector rotating clockwise in space.
- B. LHCP: Left-Hand Circular Polarization has its electric field vector rotating counter-clockwise in space.

3. Elliptical Polarization:

- A. Elliptically polarization can be either right-handed or left-handed corresponding to the electric-field vector rotating clockwise (right-handed) or counter-clockwise (left-handed) in an elliptical rotation.

Circular Polarization of EM wave

Showing projection of Horizontal & Vertical components

The power received by an antenna is maximal if the polarization of the incident wave and the polarization of the antenna have:

- ✓ The same axial ratio.
- ✓ The same sense of polarization.
- ✓ The same spatial orientation.

		Field Polarization			
		Vertical	Horizontal	Right hand Circular	Left hand Circular
Antenna Polarization	Vertical	0 dB	∞	3 dB	3 dB
	Horizontal	∞	0 dB	3 dB	3 dB
	Right hand Circular	3 dB	3 dB	0 dB	∞
	Left hand Circular	3 dB	3 dB	∞	0 dB

Attenuation due to Polarization Mismatch

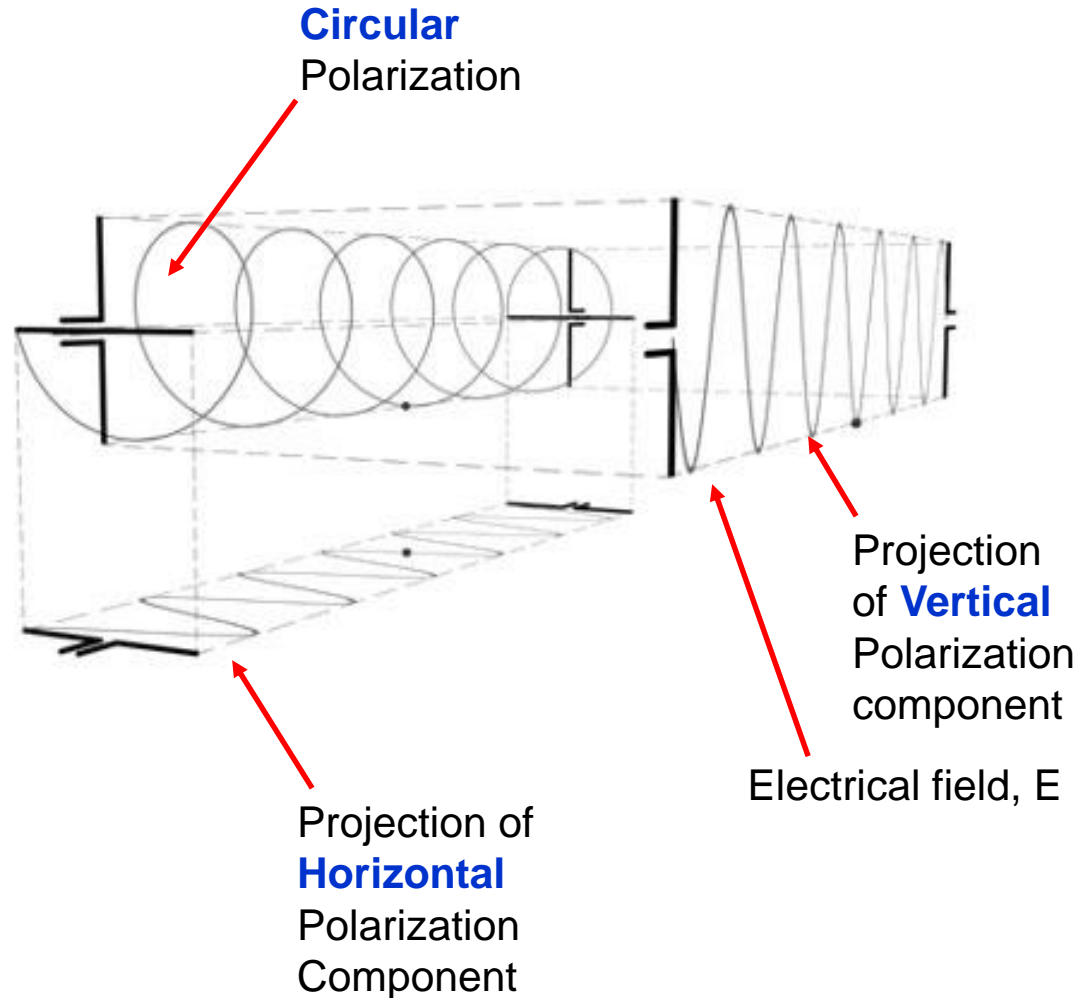

Power Transfer into Free Space

Friis' Transmission Equation



1. In any communication link, there is a transmitting antenna with directional gain G_t radiating to a receive antenna with directional gain G_r that are separated by a distance R .
2. The power flux density, PFD, at any given range: R meters, from an ideal lossless isotropic antenna radiating a transmit power P_t is:

$$PFD_{isotropic} = \frac{P_t}{4\pi R^2}, \text{Watts} / m^2, \text{ where the area of a sphere is: } A_{sphere} = 4\pi R^2, m^2$$

3. The power flux density focused in the direction of maximum radiation by a transmit antenna having a directional gain G_t is:

$$PFD_t = PFD_{isotropic} \cdot G_t = \frac{P_t G_t}{4\pi R^2}, \text{watts} / m^2 \quad \text{where: } EIRP = P_t G_t$$

4. The signal power received (P_{rec}) by an antenna having an effective aperture area: $A_{e,r}$ is:

$$P_{rec} = PFD_t \cdot A_{e,r} = \left(\frac{P_t G_t}{4\pi R^2} \right) \cdot A_{e,r} = P_t G_t G_r \left(\frac{\lambda}{4\pi R} \right)^2, \text{watts} \quad \text{where: } A_{e,r} = \frac{\lambda^2}{4\pi} \cdot G_r$$

5. Rearranging, one obtains Friis' Transmission Equation:

$$\frac{P_{rec}}{P_t} = \frac{G_t G_r}{(4\pi R / \lambda)^2}, \text{ where Free Space Path Loss: } FSPL = (4\pi R / \lambda)^2$$

"Note on a Simple Transmission Formula", Harald Friis,
 Proceeding of IRE, Vol 34, p 254-256, May 1946.

Atlanta RF

Services, Software & Designs

Friis' Transmission Equation with Loss

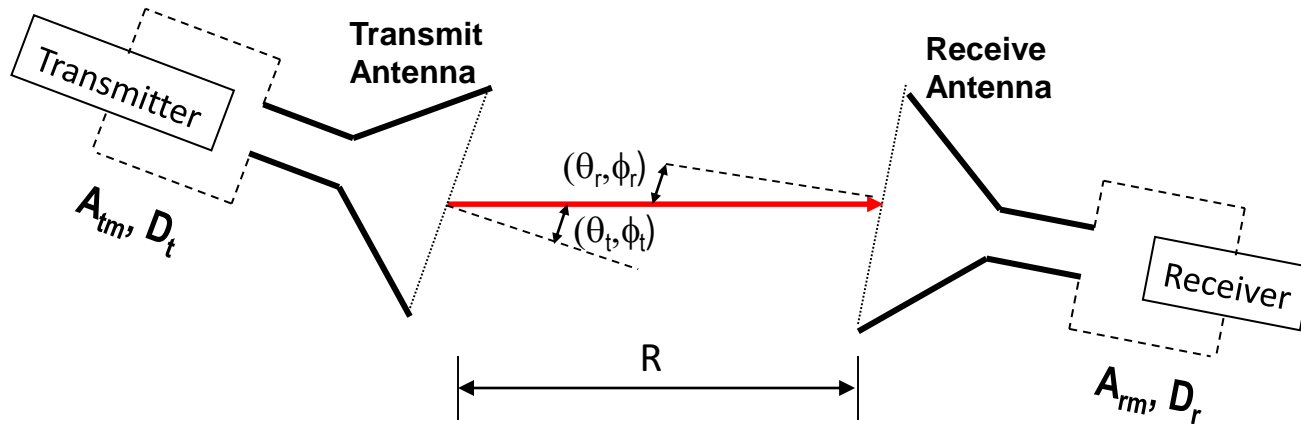

Conductor and Dielectric losses in Receive antenna.

Reflection loss in Receive antenna (impedance mismatch).

Free Space Path Loss.

Directivity of Receive antenna.

$$\frac{P_r}{P_t} = \eta_{cdt} \eta_{cdr} (1 - |\Gamma_r|^2) (1 - |\Gamma_t|^2) \left(\frac{\lambda}{4\pi R} \right)^2 D_{gt}(\theta_t, \phi_t) D_{gr}(\theta_r, \phi_r) |\hat{\rho}_w \cdot \hat{\rho}_a^*|^2$$

Conductor and Dielectric losses in Transmit antenna.

Reflection loss in Transmit antenna (impedance mismatch).

Directivity of Transmit antenna.

Polarization Mismatch.

Free-Space Path Loss vs Distance: R

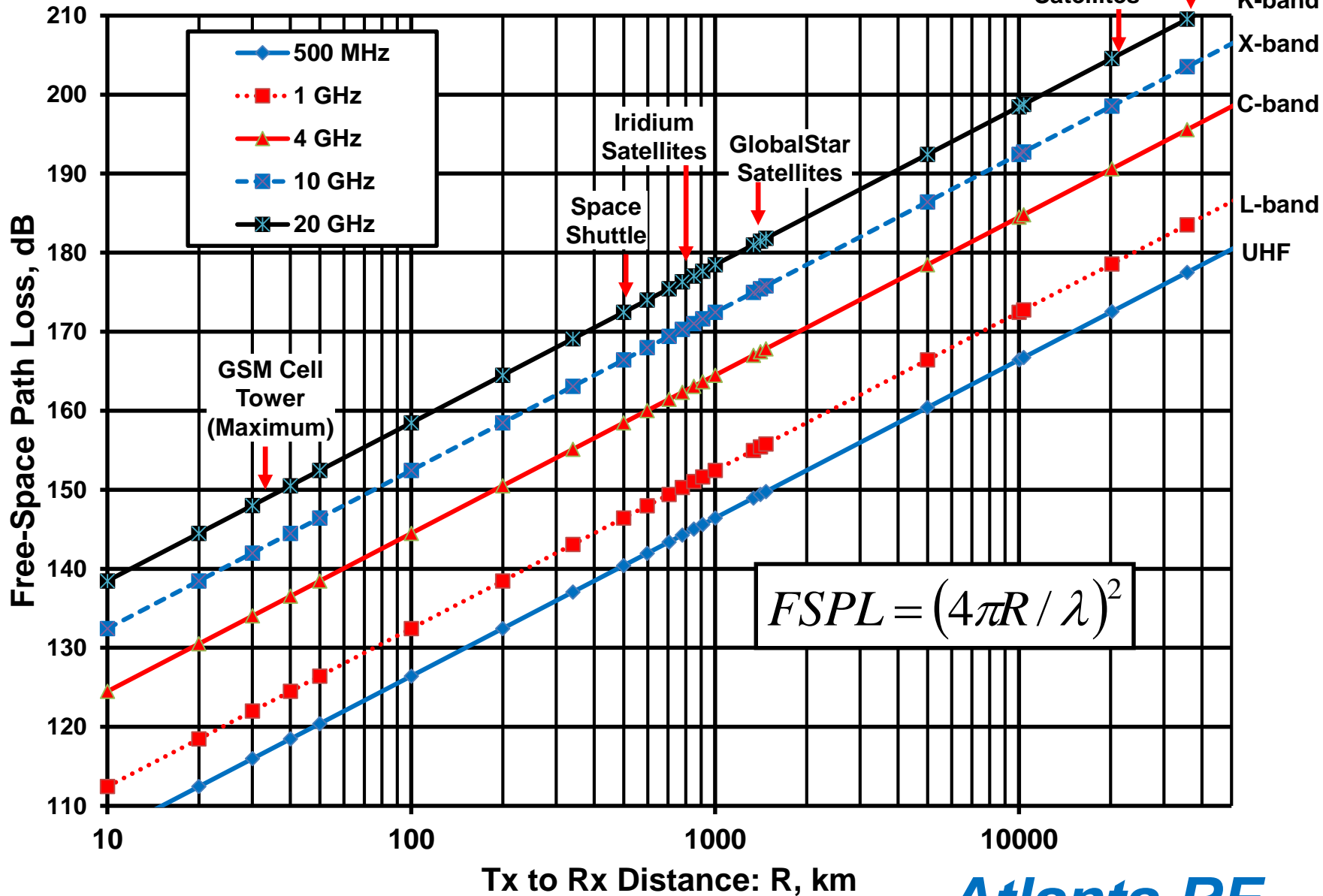

Phased Array Antennas

1. A single antenna may not provide the radiation pattern nor the agility needed to satisfy the performance requirements of a system or network . However, a proper combination of many antennas might satisfy those requirements.
2. An antenna array is a cluster of N antennas arranged in a linear, planar or conformal spatial configuration (line, circle, grid, etc.). Each individual antenna is called an element of the array, and they are typically identical antenna elements.
3. The excitation applied to each individual antenna element (both amplitude and phase) is electronically-controlled (“software defined”) to enable the composite array to radiate beams of energy quickly (~msec) with a desired radiation pattern across a selected coverage area, like: Narrow focused beams, Fan-shaped beams, and Multiple beams (array thinning) from AESAs.
 - A. The amplitude (RF power level) applied to each individual antenna element is controlled by a Transmit/Receive (T/R) module in Active Electronically Scanned Arrays (AESAs).
 - B. The phase excitation applied to each individual antenna element is controlled by phase shifters: Diode phase shifters, MEMS phase shifters or ferrite phase shifters in Passive Electronically Scanned Arrays (PESA), while T/R Modules also contain phase shifters for AESAs.

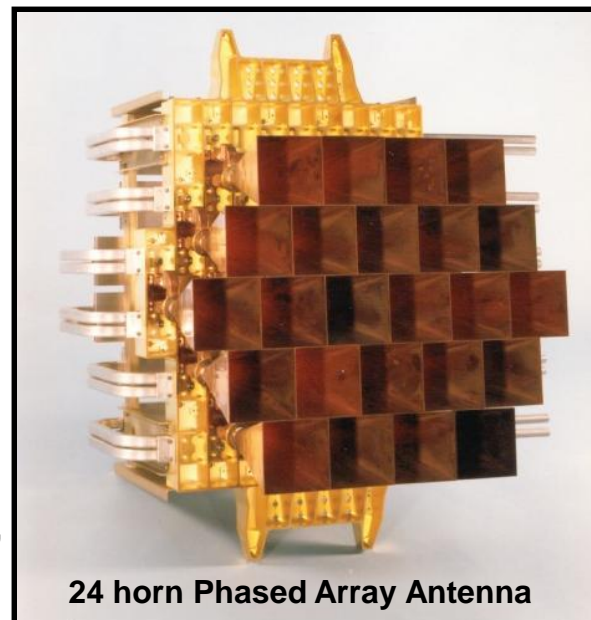

Benefits of Phased Array Antennas

1. Phased array antennas can steer the main radiation beam rapidly (~msec) without physically moving the antenna: Inertia-less beamforming & scan.
 - A. Rotating a single antenna is slow. . . .reaction time is long (many seconds).
 - B. Can eliminate mechanical errors during beam scan.
 - C. Higher reliability than mechanically rotating antennas → Low maintenance.
2. Phased Array Antennas can electronically-control the:
 - A. Instantaneous beam position → Beam agility.
 - 1) Multi-mode operation: Frequency scan, time-delay scan, phase scan.
 - 2) Multi-target capability: Search, Track & Scan.
 - B. Half-power beamwidth (HPBW).
 - C. Antenna's Directivity/Gain.
 - D. Level of radiated sidelobes.
 - E. Direction/position of amplitude nulls.
3. General design trade-offs for Phased Array Antennas:
 - A. Array configuration: Linear, circular, planar, etc.
 - B. Element spacing; typically 0.5λ to 0.6λ to prevent grating lobes in visible space.
 - A. Amplitude excitation applied to each element.
 - B. Phase excitation applied to each element.
 - C. Patterns of array elements.

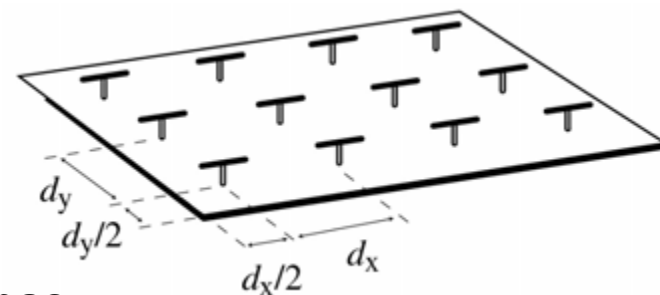

3x4-element Dipole Array

Phased Array Antenna Configurations

Active Phased Array & Passive Phased Array

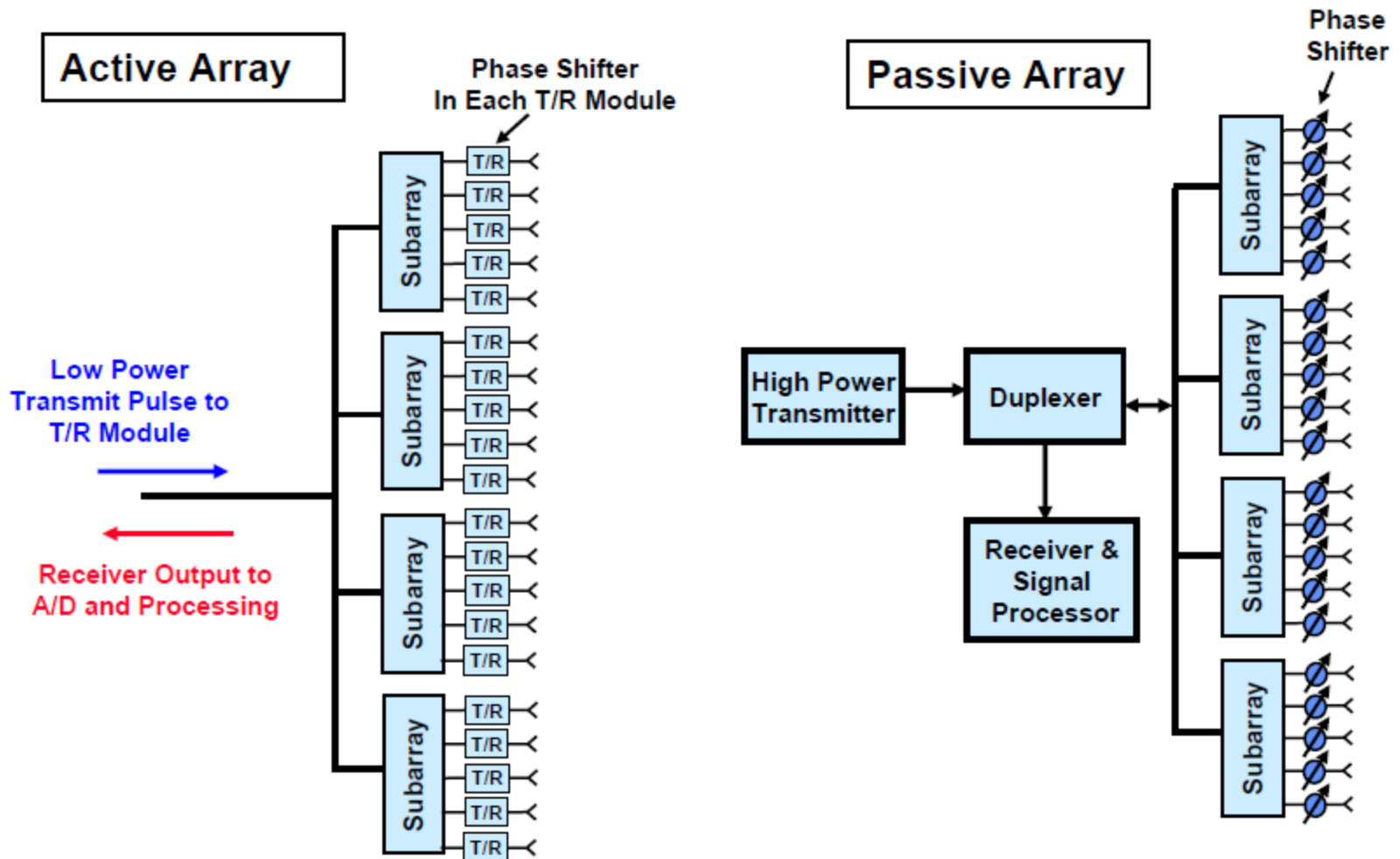

Atlanta RF

Services, Software & Designs

Military/Defense Phased Array Evolution

Passive Array

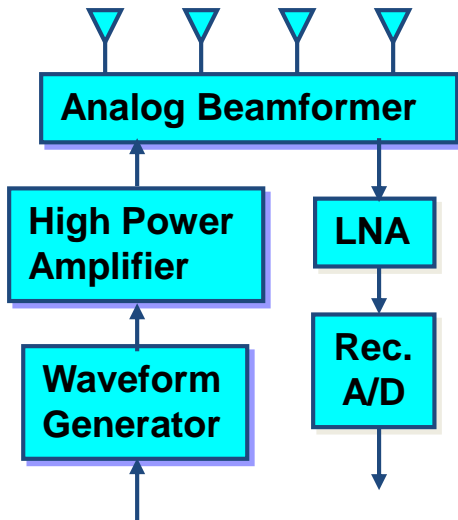

Installed on AEGIS ship; AN/SPY-1 Radar

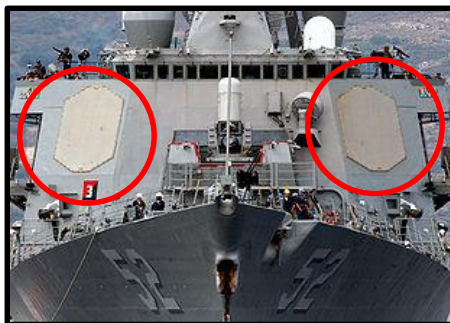

Active Element

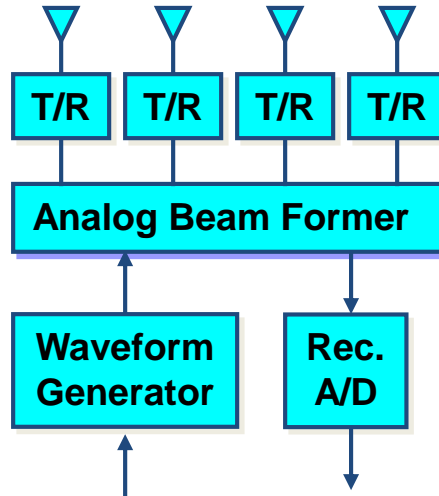

Used for Volume Search Radar



Digital Array

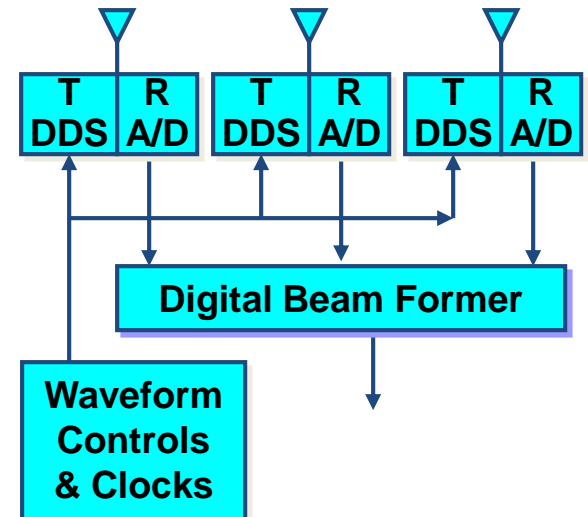

Future Radar

Digital Beam Forming

- Multi-beam operation

Flexible time energy management
Power Aperture Gain Improvement

- Large high power aperture

Atlanta RF

Services, Software & Designs

Beam Steering using Phase Shifters

Passive Electronically Scan Array (PESA)

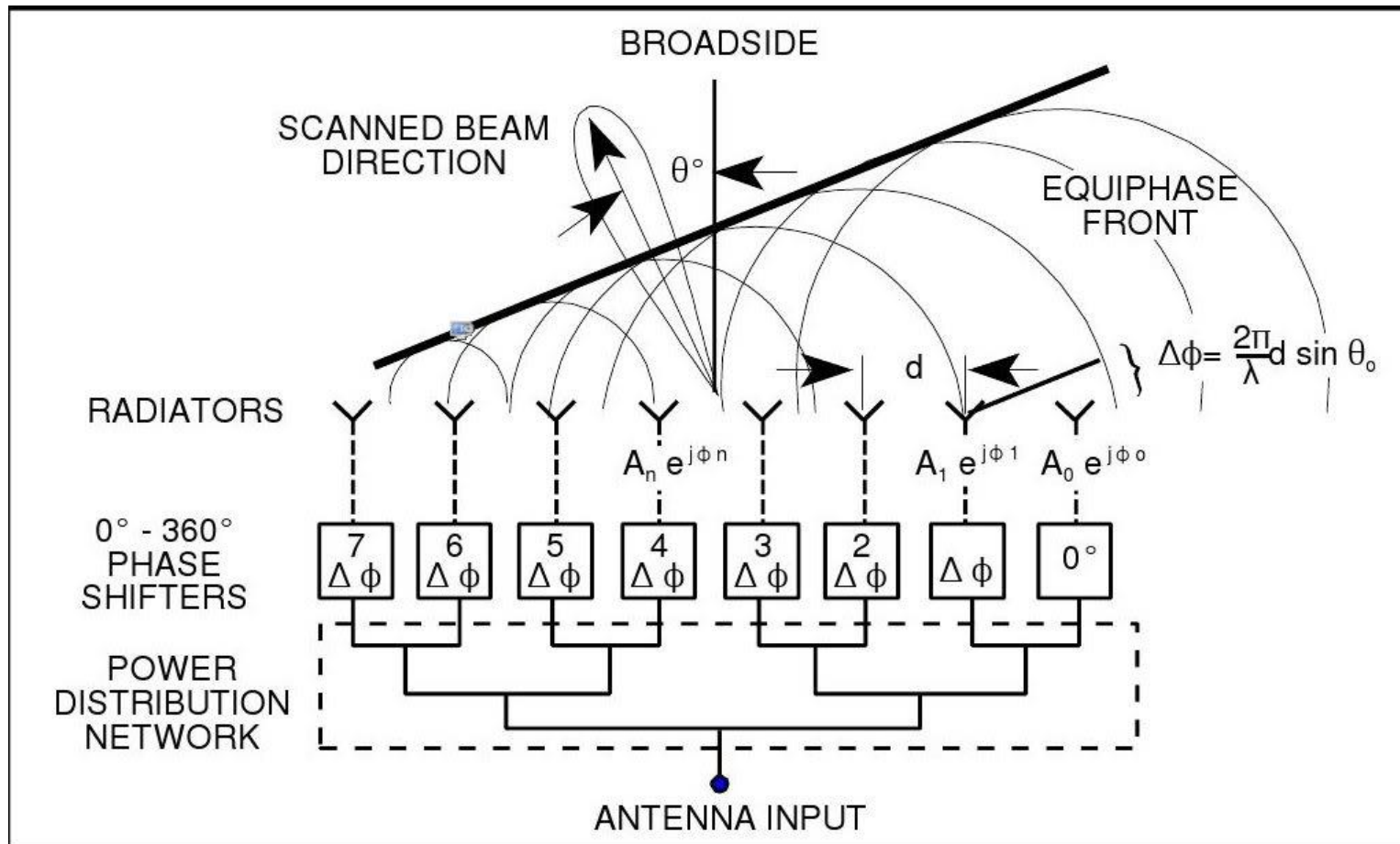

Phased Array Antenna's Gain & Beamwidth

1. The Gain of a phase array antenna is a function of the number of elements, N, in the array and the gain of the individual elements: G_e .
 - A. For half-wavelength element spacing, the gain at boresight is given by:
$$\text{Gain} = 10 \log_{10} (N) + G_e , \text{ dB}$$
 - B. The gain off-boresight is reduced by the cosine of the steering angle, φ_s :
$$\text{Gain} = 10 \log_{10} (N) + G_e + 10 \log_{10} (\cos \varphi_s)$$
2. The Beamwidth of a phased array antenna is a function of the number of elements, N:
 - A. For a half-wavelength phased array of dipole elements, the half-power beamwidth (HPBW) is given by:
$$\theta_{3\text{dB}} = 102/N$$
 - B. The beamwidth at steering angles off boresight increases with the cosine of φ_s :
$$\theta_{3\text{dB}} = (102/N) / \cos(\varphi_s)$$

Characteristics of Antennas

Some **characteristics** and typical **applications** for certain antennas:

1. Half-Wave Dipole Antenna.
2. Monopole Antenna.
3. Loop Antenna.
4. Axial-Mode Helical Antenna.
5. Yagi Antenna.
6. Log Periodic Antenna.
7. Cavity-backed Spiral Antenna.
8. Conical Spiral Antenna.
9. Horn Antenna.
10. Parabolic Antenna.
11. Phased Array Antenna.



Half-wave Dipole Antenna

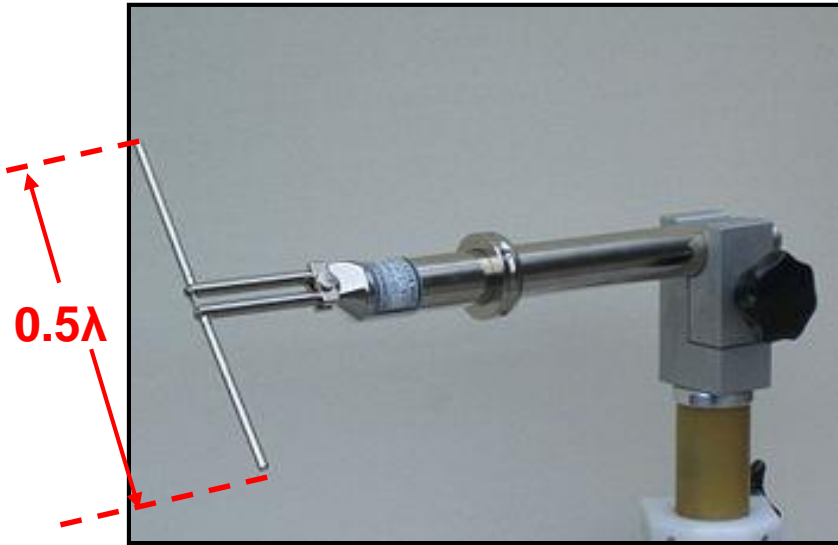

Typical Radiation Field Pattern

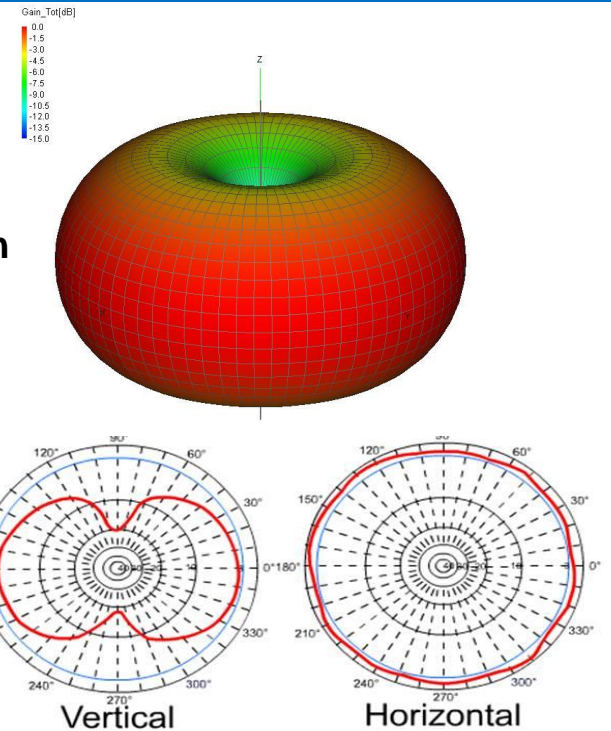

Typical Radiation Pattern Polar Plot

Characteristics:

- Polarization: Vertical.
- Beamwidth: $\sim 78^\circ \times 360^\circ$ (Az).
- Frequency Limit:
 - Lower Limit: ~ 2 MHz.
 - Upper Limit: ~ 8 GHz.
- Bandwidth: 10% (1.1:1).
- Gain: 2.15 dB.

Typical Applications:

- Wireless Local Area Networks.
- VHF TV “Rabbit ears”.
- FM radio (folded dipole).
- Radio mast transmitters.



Atlanta RF

Services, Software & Designs

Monopole (Whip) Antenna

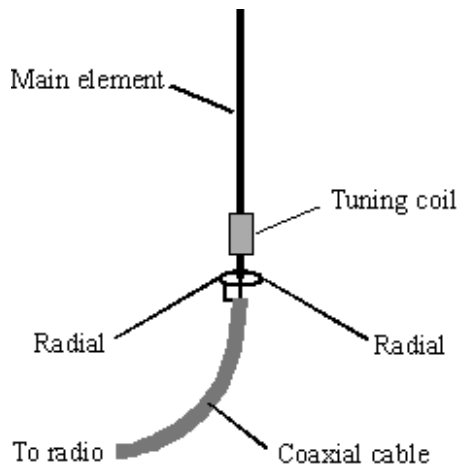

Elevation Radiation Pattern

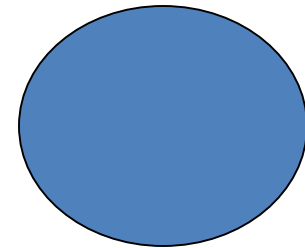

Azimuth Radiation Pattern

Characteristics:

- Polarization: Linear.
- Beamwidth: $\sim 45^\circ \times 360^\circ$ (Az).
- Frequency Limits:
 - Lower Limit: None.
 - Upper Limit: None.
- Bandwidth: 10% (1.1:1).
- Gain: 0 dB to 2 dB.

Typical Applications:

- Automobile radio and satellite signal reception.
- Military communications.

Loop Antenna

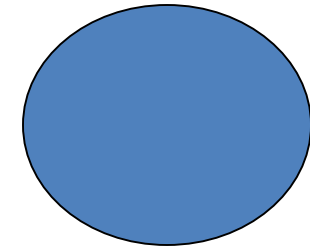

Elevation Radiation Pattern

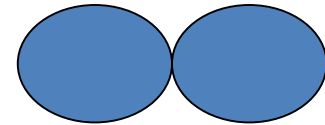

Azimuth Radiation Pattern

Characteristics:

- Polarization: Horizontal.
- Beamwidth: $\sim 80^\circ \times 360^\circ$ (Az).
- Frequency Limits:
 - Lower Limit: 50 MHz.
 - Upper Limit: 1 GHz.
- Bandwidth: 10% (1.1:1).
- Gain: -2 dB to 2 dB.

Typical Applications:

- TV reception: UHF channels.
- AM Broadcasting.

Atlanta RF

Services, Software & Designs

Axial-Mode Helical Antenna

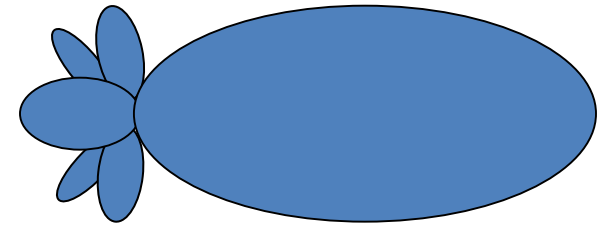

$$Gain \approx 15 \frac{N \times S \times C^2}{\lambda^3}$$

where:

- C = Circumference of helix($\sim\lambda$).
- S = Turn spacing between coils.
- N = Number of turns (>3).

EI & Az Radiation Pattern

Characteristics:

- Polarization: Circular.
- Beamwidth: $50^\circ \times 50^\circ$.
- Frequency Limits:
 - Lower Limit: 100 MHz.
 - Upper Limit: ~ 8 GHz.
- Bandwidth: 20% to 70%.
- Gain: 10 dB to 20 dB.

Typical Applications:

- Mobile communications.
- Global Positioning System.
- Space communication.
- Animal tracking.

Atlanta RF

Services, Software & Designs

Yagi Antenna

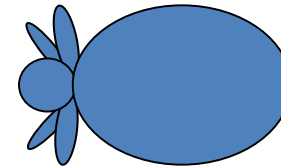
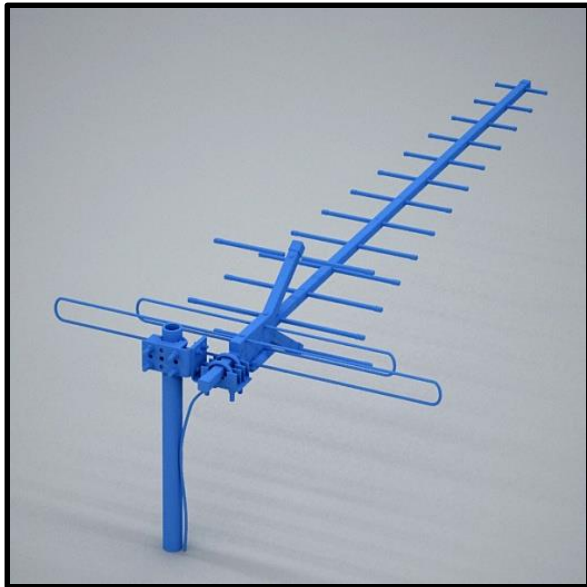

Elevation Radiation Pattern

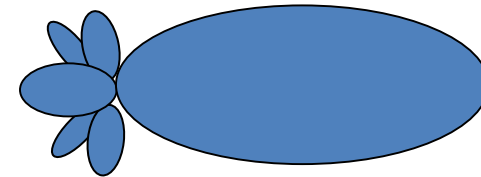

Azimuth Radiation Pattern

Characteristics:

- Polarization: Horizontal.
- Beamwidth: $50^\circ \times 50^\circ$
- Frequency Limits:
 - Lower Limit: 50 MHz.
 - Upper Limit: 2 GHz.
- Bandwidth: 5% (1.05:1).
- Gain: 5 dB to 15 dB.

Typical Applications:

- WWII airborne radar.
- Amateur radio.
- TV reception: UHF & VHF.
- FM Radio reception.

Atlanta RF

Services, Software & Designs

Log Peroidic Antenna

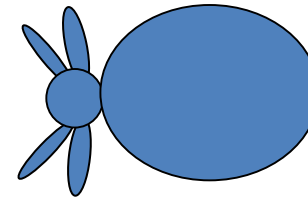
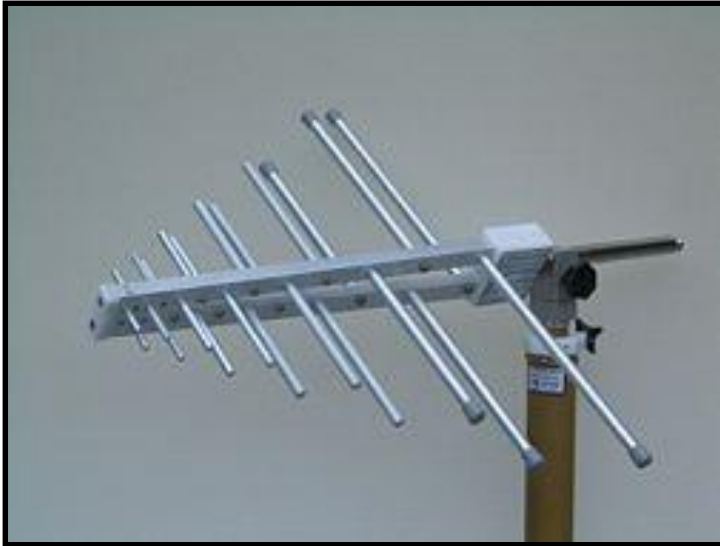

Elevation Radiation Pattern

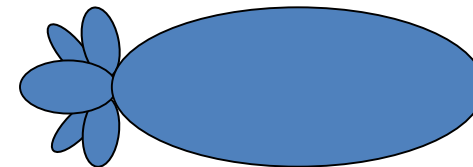

Azimuth Radiation Pattern

Characteristics:

- Polarization: Linear.
- Beamwidth: $60^\circ \times 80^\circ$
- Frequency Limits:
 - Lower Limit: 3 MHz.
 - Upper Limit: 18 GHz.
- Bandwidth: 163% (10:1).
- Gain: 6 dB to 8 dB.

Typical Applications:

- TV reception: UHF & VHF.
- FM Radio reception.
- Amateur radio.

Cavity-Backed Spiral Antenna

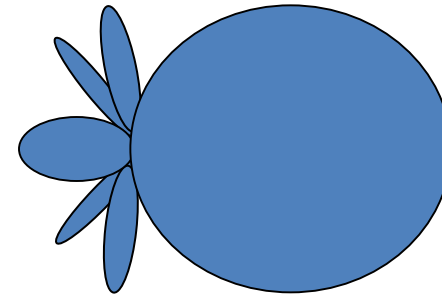
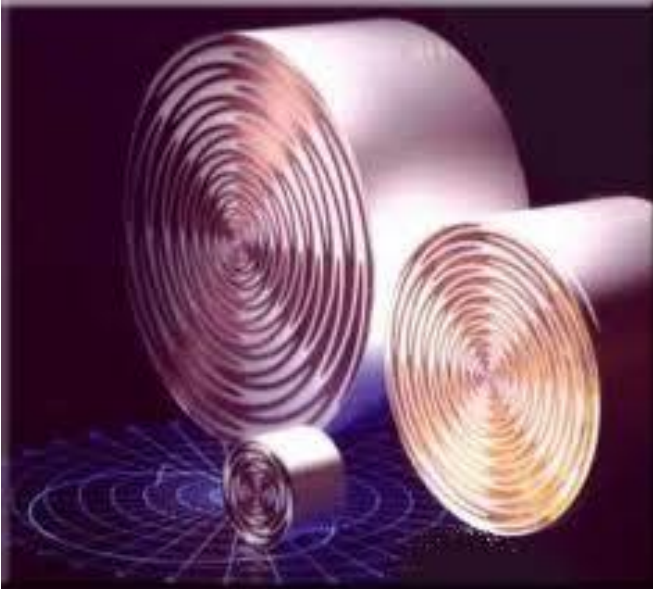

EI & Az Radiation Pattern

Characteristics:

- Polarization: Circular.
- Beamwidth: $80^\circ \times 80^\circ$.
- Frequency Limits:
 - Lower Limit: 500 MHz.
 - Upper Limit: 18 GHz.
- Bandwidth: 160% (9:1).
- Gain: 2 dB to 4 dB.

Typical Applications:

- Radar altimeter.
- Electronic warfare.

Conical Spiral Antenna

Radome installed



Radome removed

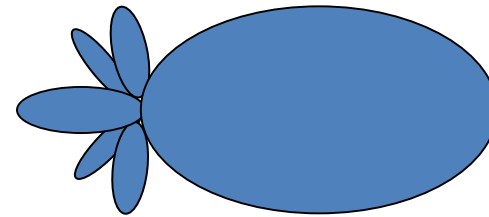

EI & Az Radiation Pattern

Characteristics:

- Polarization: Circular.
- Beamwidth: $60^\circ \times 60^\circ$.
- Frequency Limits:
 - Lower Limit: 50 MHz.
 - Upper Limit: ~40 GHz.
- Bandwidth: 120% (4:1).
- Gain: -9 dB to +8 dB.

Typical Applications:

- Direction Finding Radar.
- Ground penetrating radar.
- Electronic warfare.
- Feeds for reflector antennas.
- Telemetry.

Horn Antenna

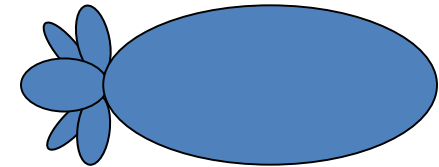
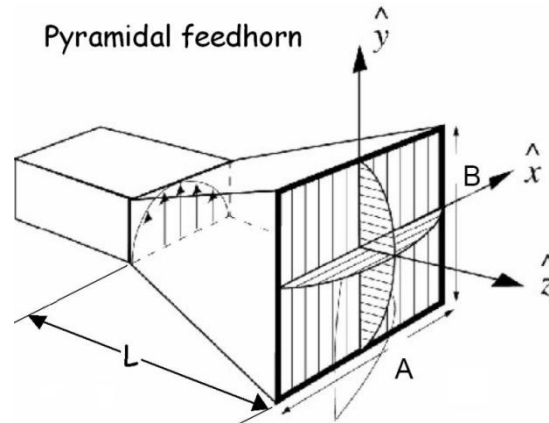

Elevation Radiation Pattern

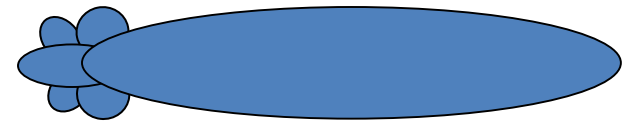

Azimuth Radiation Pattern

$$D_{rec} = \frac{4\pi}{\lambda^2} (a \cdot b)$$

$$HPBW_{xz(\theta)} \approx 51^\circ \frac{\lambda}{a}$$

$$HPBW_{yz(\phi)} \approx 51^\circ \frac{\lambda}{b}$$

Characteristics:

- Polarization: Linear / Circular.
- Beamwidth: $\sim 40^\circ \times \sim 40^\circ$.
- Frequency Limits:
 - Lower Limit: 50 MHz.
 - Upper Limit: 40 GHz.
- Bandwidth:
 - Ridged: 120% (4 :1).
 - Not Ridged: 67% (2:1) .
- Gain: 5 dB to 20 dB.

Typical Applications:

- Satellite Communication.
- Radio astronomy.
- Electronic warfare.
- Antenna testing.

$$D_{circular} = \frac{4\pi}{\lambda^2} (\pi r^2)$$

$$HPBW^o_{circular} \approx 58^\circ \frac{\lambda}{2r}$$

Atlanta RF

Services, Software & Designs

Parabolic Antenna: Prime Focus

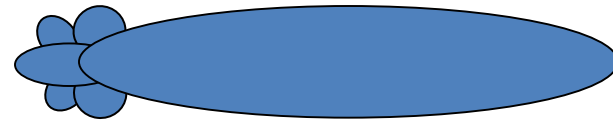

EI & Az Radiation Pattern

$$Gain = \eta_{eff} D = \eta_{eff} \left(\frac{4\pi A}{\lambda^2} \right) = \eta_{eff} \left(\frac{\pi D}{\lambda} \right)^2$$
$$HPBW \approx \frac{70^\circ \lambda}{D}$$

Characteristics:

- Polarization: Depends on feed.
- Beamwidth: $0.5^\circ \times 30^\circ$.
- Frequency Limits:
 - Lower Limit: 400 MHz.
 - Upper Limit: 30+ GHz.
- Bandwidth: 33% (1.4:1).
- Gain: 10 dB to 55 dB.

Typical Applications:

- Satellite TV.
- Point-to-Point Backhaul.
 - Cellular telephony, Wi-Fi
- Radio astronomy.
- Search & track radar.



Atlanta RF

Services, Software & Designs

Typical Parabolic Antenna Gain & HPBW

Gain versus Dish Diameter ($\eta_{\text{eff}} = 55\%$)

Diameter:	2 ft	4 ft	6 ft	8 ft	10 ft	12 ft	15 ft
Freq.	(0.6 m)	(1.2 m)	(1.8 m)	(2.4 m)	(3.0 m)	(3.7 m)	(4.5 m)
2 GHz	19.5dBi	25.5dBi	29.1dBi	31.6dBi	33.5dBi	35.1dBi	37dBi
4GHz	25.5dBi	31.6dBi	35.1dBi	37.6dBi	39.5dBi	41.1dBi	43.1dBi
6 GHz	29.1dBi	35.1dBi	38.6dBi	41.1dBi	43.1dBi	44.6dBi	46.6dBi
8 GHz	31.6dBi	37.6dBi	41.1dBi	43.6dBi	45.5dBi	47.1dBi	49.1dBi
11 GHz	34.3dBi	40.4dBi	43.9dBi	46.4dBi	48.3dBi	49.9dBi	51.8dBi
15 GHz	37dBi	43.1dBi	46.6dBi	49.1dBi	51dBi	52.6dBi	NA
18 GHz	38.6dBi	44.6dBi	48.2dBi	50.7dBi			
22 GHz	40.4dBi	46.4dBi	49.9dBi	NA			
38 GHz	45.1dBi	51.1dBi	NA	NA			

Half-Power Beamwidth (HPBW) versus Dish Diameter

Diameter:	1 ft	2 ft	4 ft	6 ft	8 ft	10 ft	12 ft	15 ft
Freq.	(0.3 m)	(0.6 m)	(1.2 m)	(1.8 m)	(2.4 m)	(3.0 m)	(3.7 m)	(4.5 m)
2 GHz	35°	17.5°	8.75°	5.83°	4.38°	3.5°	2.84°	2.33°
4 GHz	17.5°	8.75°	4.38°	2.92°	2.19°	1.75°	1.42°	1.17°
6 GHz	11.67°	5.83°	2.92°	1.94°	1.46°	1.17°	0.95°	0.78°
8 GHz	8.75°	4.38°	2.19°	1.46°	1°	0.88°	0.71°	0.58°
11 GHz	6.36°	3.18°	1.59°	1°	0.8°	0.64°	0.52°	0.42°
14 GHz	5°	2.5°	1.25°	0.83°	0.63°	0.5°	0.41°	0.33°
18 GHz	3.89°	1.94°	0.97°	0.65°	0.49°	0.39°	0.32°	0.26°
23 GHz	3°	1.52°	0.76°	0.51°	0.38°	0.3°	0.25°	0.2°
38 GHz	1.84°	0.92°	0.46°	0.31°	0.23°	0.18°	0.15°	0.12°

$$Gain = \eta_{\text{eff}} D = \eta_{\text{eff}} \left(\frac{4\pi A}{\lambda^2} \right) = \eta_{\text{eff}} \left(\frac{\pi D}{\lambda} \right)^2$$

$$HPBW = \frac{70^\circ \lambda}{D}$$

Some Earth Station Antennas

Four reflector antenna configurations are commonly used for earth station applications:

<u>Type of Reflector Antenna</u>	<u>Configuration</u>	<u>Dish Diameters</u>
1. Prime Focus Axisymmetric	Prime focus	0.6 to 7.0 meters
2. Axisymmetric Dual Reflector	Cassegrain	2.0 to 32. meters
3. Single offset	Offset feed	0.6 to 3.6 meters
4. Dual offset	Offset feed	0.6 to 8.0 meters



Prime Focus Axisymmetric



Axisymmetric Dual Reflector



Dual Offset Reflector Antenna

Phased Array Antenna

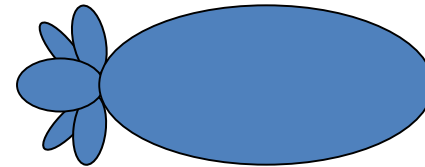

Elevation Radiation Pattern

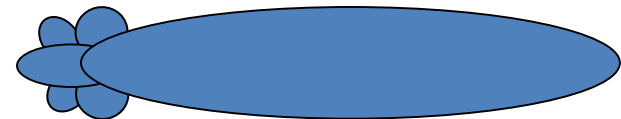

Azimuth Radiation Pattern

Characteristics:

- Polarization: Linear / Circular.
- Beamwidth: $0.5^\circ \times 30^\circ$
- Bandwidth: Varies.
- Gain: 10 to 40+ dB.

Typical Applications:

- Radio broadcasting.
- Search & track Radar & Sonar.
- Earth crust mapping; oil exploration.
- High resolution imaging of universe.
- Synthetic Aperture Radar.
- Weather radar (MPAR).

Summary: Antenna Overview

1. Many antennas and antenna arrays are available to produce radiation patterns suitable for a wide variety of applications.
2. The commercial & military defense industry continue to explore alternate antenna configurations to reduce their size & mass, while enabling them to perform across ever increasing frequency ranges.
3. Antenna designs continue to evolve as the operating frequency expands beyond Ka-band and into higher millimeter-wave bands.
4. Novel antenna designs are being further integrated with back-end electronics to produce embedded & conformal structures at low to modest costs during full-rate production.



Atlanta RF

Services, Software & Designs

Atlanta RF LLC was founded to provide engineering solutions, design software solutions, and product development solutions to the high-frequency RF/microwave industry in the areas of: Telecommunications (ground segment), Satellite (space segment) and military/defense (RF front-ends).

Through teamwork, Atlanta RF applies our diverse technical experience to your project's challenges with creative and innovative solutions while holding ourselves accountable for the results. With professionalism and commitment to our clients, Atlanta RF will be there for you, both today and tomorrow

Contact Atlanta RF by e-mail at:

- Atlanta RF **Services** : Services@AtlantaRF.com
- Atlanta RF **Software** : Sales@AtlantaRF.com
- Atlanta RF **Designs** : Designs@AtlantaRF.com

Or, contact Atlanta RF by phone at: 678-445-5544, to reach our Atlanta-area office in Georgia, USA, and discuss our support to your current or future projects & products.

Atlanta RF

Services, Software & Designs

Presentations by Atlanta RF, LLC

Download various presentations at our website: www.AtlantaRF.com :

1. Satellite: LEO, MEO & GEO.
2. Antennas: An Overview.
3. Link Budget: Getting Started.
4. Link Budget: Digital Modulation Part 1 (Overview & M-ASK).
5. Link Budget: Digital Modulation Part 2 (M-FSK).
6. Link Budget: Digital Modulation Part 3 (M-PSK & QAM).
7. Link Budget: Error Control & Detection.
8. Multiple Access Techniques: FDMA, TDMA and CDMA.
9. Insertion Loss: Double Ridge Waveguide.
10. RF Filters: An Overview.
11. Multi-Section Symmetrical Directional Couplers.
12. Parallel Coupled Bandpass Filters.

Visit our website often as presentations are added for your viewing pleasure.

Atlanta RF

Services, Software & Designs